



FAIRBANKS NIJHUIS™

MODEL 1820
HORIZONTAL SPLIT-CASE PUMPS
INSTALLATION, OPERATION AND MAINTENANCE MANUAL

NOTE! To the installer: Please make sure you provide this manual to the owner of the equipment or to the responsible party who maintains the system.

WARRANTY

WARRANTY HIGHLIGHTS

1. Seller warrants products of its own manufacture and workmanship under normal use and service according to previously submitted terms & conditions letter or form KC585.
2. Accessories and components not manufactured by seller are warranted only to the extent of the original manufacturer's warranty.
3. No allowances will be made for repairs or alterations effected without specific written authorization from seller.
4. Repairs or alterations made with other than genuine Fairbanks Nijhuis™ original equipment parts may void the warranty and relieve the seller of all product responsibility.
5. This warranty is void unless the purchaser provides protective storage, installs and maintains the equipment in accordance with manufacturer's instructions.
6. Under the terms of this warranty, seller shall not be responsible nor liable for:
 - a. Consequential, collateral or special losses or damages.
 - b. Equipment conditions caused by fair wear and tear, abnormal conditions of use, accident, neglect, or misuse of said equipment.
 - c. Labor charges, loss or damage resulting from supplying of defective part(s) or improper repairs by unauthorized person(s).
 - d. Damage caused by abrasive materials, chemicals, scale deposits, corrosion, lightning, improper voltage or mishandling.
7. The above listed warranty highlights do not constitute our total terms and conditions regarding warranty.

DELIVERY: Buyer agrees to inspect all deliveries immediately. Any claim for shortages must be made in writing within ten (10) days after Buyer receives a shipment, and if not made, shall be deemed waived. Any other claim by Buyer, other than claims under the warranty stated in Paragraph 13, shall be made within thirty (30) days after Buyer receives shipment, and if not made shall be deemed waived. Seller is not responsible for loss or damage in transit after having received an "In Good Order" receipt from the carrier. Buyer will make all claims for loss or damage in transit against the carrier.

Buyer is fully responsible for (including payment of the cost of) installation and start-up of all equipment sold under the Order.

PATENT INFRINGEMENT: Seller will defend Buyer and the user of the equipment against any claim that any equipment and parts of Seller's manufacture furnished under the Order infringe upon any published United States patent, and Seller will pay all damages and costs awarded by a court of competent jurisdiction with respect to such claim. The Buyer or user must promptly notify Seller of any such claim, and cooperate fully with Seller in the defense of such claim, or Seller will have no duty under this paragraph. Buyer will defend and indemnify Seller against patent infringement claims relating to equipment and parts that are not manufactured by Seller to the same extent as Seller agrees to defend and indemnify Buyer with respect to patent infringement claims relating to equipment and parts of Seller's manufacture.

WARRANTY: Seller warrants equipment (and its component parts) of its own manufacture against defects in materials and workmanship under normal use and service for one (1) year from the date of installation or start-up, or for eighteen (18) months after the date of shipment, whichever occurs first. Seller does not warrant accessories or components that are not manufactured by Seller however, to the extent possible, Seller agrees to assign to Buyer its rights under the original manufacturer's warranty, without recourse to Seller. Buyer must give Seller notice in writing of any alleged defect covered by this warranty (together with all identifying details, including the serial number, the type of equipment, and the date of purchase) within thirty (30) days of the discovery of such defect during the warranty period. No claim made more than 30 days after the expiration of the warranty period shall be valid.

Guarantees of performance and warranties are based on the use of original equipment manufactured (OEM) replacement parts. Fairbanks Nijhuis™ assumes no responsibility or liability if alterations, non-authorized design modifications and/or non-OEM replacement parts are incorporated.

If requested by Seller, any equipment (or its component parts) must be promptly returned to Seller prior to any attempted repair, or sent to an authorized service station designed by Seller, and Buyer shall prepay all shipping expenses. Seller shall not be liable for any loss or damage to goods in transit, nor will any warranty claim be valid unless the returned goods are received intact and undamaged as a result of shipment. Repaired or replaced material returned to customer will be shipped F.O.B., Seller's factory. Seller will not give Buyer credit for parts or equipment returned to Seller, and will not accept delivery of any such parts or equipment, unless Buyer has obtained Seller's approval in writing.

The warranty extends to repaired or replaced parts of Seller's manufacture for ninety (90) days or for the remainder of the original warranty period applicable to the equipment or parts being repaired or replaced. This warranty applies to the repaired or replaced part and is not extended to the product or any other component of the product being repaired.

Repair parts of its own manufacture sold after the original warranty period are warranted for a period of one (1) year from shipment

against defects in materials and workmanship under normal use and service. This warranty applies to the replacement part only and is not extended to the product or any other component of the product being repaired.

Seller may substitute new equipment or improve part(s) of any equipment judged defective without further liability. All repairs or services performed by Seller, which are not covered by this warranty, will be charged in accordance with Seller's standard prices then in effect.

THIS WARRANTY IS THE SOLE WARRANTY OF SELLER AND SELLER HEREBY EXPRESSLY DISCLAIMS AND BUYER WAIVES ALL OTHER WARRANTIES EXPRESSED, IMPLIED IN LAW OR IMPLIED IN FACT, INCLUDING ANY WARRANTIES OF MERCHANTABILITY OR FITNESS FOR A PARTICULAR PURPOSE. Seller's sole obligation under this warranty shall be, at its option, to repair or replace any equipment (or its component parts) which has a defect covered by this warranty, or to refund the purchase price of such equipment or part. Under the terms of this warranty, Seller shall not be liable for (a) consequential, collateral, special or liquidated losses or damages;

(b) equipment conditions caused by normal wear and tear, abnormal conditions of use, accident, neglect, or misuse of said equipment; (c) the expense of, and loss or damage caused by, repairs or alterations made by anyone other than the Seller;

(d) damage caused by abrasive materials, chemicals, scale deposits, corrosion, lightning, improper voltage, mishandling, or other similar conditions; (e) any loss, damage, or expense relating to or resulting from installation, removal or reinstallation of equipment; (f) any labor costs or charges incurred in repairing or replacing defective equipment or parts, including the cost of reinstalling parts that are repaired or replaced by Seller; (g) any expense of shipment of equipment or repaired or replacement parts; or (h) any other loss, damage or expense of any nature.

CONDITION TO WARRANTY WORK: If Buyer is in default (including, but not limited to, the failure of Buyer to maintain a current account with Seller) under the Order or any other agreement between Buyer and Seller, Buyer's rights under the warranty shall be suspended and the original warranty period will not be extended.

PERFORMANCE: Equipment performance is not warranted or guaranteed unless separately agreed to by Seller in accordance with its guarantee policy. Performance curves and other information submitted to Buyer are approximate and no warranty or guarantee shall be deemed to arise as a result of such submittal. All testing shall be done in accordance with Seller's standard policy.

LIABILITY LIMITATIONS: Under no circumstances shall the Seller have any liability under the Order or otherwise for liquidated damages or for collateral, consequential or special damages or for loss of profits, or for actual losses or for loss of production or progress of construction, regardless of the cause of such damages or losses. In any event, Seller's aggregate total liability under the Order or otherwise shall not exceed the contract price. Buyer agrees to indemnify and hold harmless Seller from all claims by third parties in excess of these limitations.

COMPLIANCE WITH LAW: Since the compliance with the various Federal, State, and Local laws and regulations concerning occupational health and safety and pollution are affected by the use, installation and operation of the equipment and other matters over which Seller has no control, Seller assumes no responsibility for compliance with those laws and regulations, whether by way of indemnity, warranty, or otherwise.



FAIRBANKS NIJHUIS™

Prestart-Up and Start-Up Check List

Contractor _____

Pump Serial Number _____

Project Name _____

Pump Model Number _____

Procedure	Yes	No	N/A	Comments
1. Shipment				
Was there any damage in transit?	<input type="checkbox"/>	<input type="checkbox"/>	<input type="checkbox"/>	
Were all items received?	<input type="checkbox"/>	<input type="checkbox"/>	<input type="checkbox"/>	
2. Storage				
Has equipment been protected from inclement weather?	<input type="checkbox"/>	<input type="checkbox"/>	<input type="checkbox"/>	
Was equipment subject to flooding?	<input type="checkbox"/>	<input type="checkbox"/>	<input type="checkbox"/>	
Have all bearings been protected from moisture?	<input type="checkbox"/>	<input type="checkbox"/>	<input type="checkbox"/>	
3. Installation				
Were retaining fasteners, used in shipping, removed prior to installation?	<input type="checkbox"/>	<input type="checkbox"/>	<input type="checkbox"/>	
Is grouting under base properly compacted?	<input type="checkbox"/>	<input type="checkbox"/>	<input type="checkbox"/>	
Is grouting of the non-shrink type?	<input type="checkbox"/>	<input type="checkbox"/>	<input type="checkbox"/>	
Have proper anchor bolts been used?	<input type="checkbox"/>	<input type="checkbox"/>	<input type="checkbox"/>	
Have the bolts been properly tightened?	<input type="checkbox"/>	<input type="checkbox"/>	<input type="checkbox"/>	
Have both the suction and discharge been checked for pipe strain?	<input type="checkbox"/>	<input type="checkbox"/>	<input type="checkbox"/>	
Are lube lines and seal water lines properly installed?	<input type="checkbox"/>	<input type="checkbox"/>	<input type="checkbox"/>	
Are accessory items, RTD's, bearing temp detectors, vibration sensors, etc. mounted and properly installed?	<input type="checkbox"/>	<input type="checkbox"/>	<input type="checkbox"/>	
Are lube lines purged of air and lubricant added? (pump and driver)	<input type="checkbox"/>	<input type="checkbox"/>	<input type="checkbox"/>	
Are all safety guards in place?	<input type="checkbox"/>	<input type="checkbox"/>	<input type="checkbox"/>	
Have impellers been checked for proper clearance?	<input type="checkbox"/>	<input type="checkbox"/>	<input type="checkbox"/>	
4. Alignment				
Has the alignment of driver to pump been checked?	<input type="checkbox"/>	<input type="checkbox"/>	<input type="checkbox"/>	
Have indicator readings been taken?	<input type="checkbox"/>	<input type="checkbox"/>	<input type="checkbox"/>	
5. Rotation				
Has the rotation of the drives been checked for correctness?	<input type="checkbox"/>	<input type="checkbox"/>	<input type="checkbox"/>	
Has the coupling been turned to assure free rotation of pump and motor?	<input type="checkbox"/>	<input type="checkbox"/>	<input type="checkbox"/>	
6. System				
Has the system been checked to insure that it is free of foreign matter which could be damaging to the pump?	<input type="checkbox"/>	<input type="checkbox"/>	<input type="checkbox"/>	
Is liquid available to the pump?	<input type="checkbox"/>	<input type="checkbox"/>	<input type="checkbox"/>	
Has assurance been obtained from responsible parties that all piping is secure and that the routing of flow has been established and is correct?	<input type="checkbox"/>	<input type="checkbox"/>	<input type="checkbox"/>	
7. Start-Up				
Has flow been established?	<input type="checkbox"/>	<input type="checkbox"/>	<input type="checkbox"/>	
Have guage readings been taken?	<input type="checkbox"/>	<input type="checkbox"/>	<input type="checkbox"/>	
Has packing been adjusted to insure proper lubriation of packing?	<input type="checkbox"/>	<input type="checkbox"/>	<input type="checkbox"/>	
If pumps are equipped with mechanical seals, is the lubricating seal water pressure a constant 10 to 15 p.s.i. above the discharge of the pump?	<input type="checkbox"/>	<input type="checkbox"/>	<input type="checkbox"/>	
Is excessive vibration present?	<input type="checkbox"/>	<input type="checkbox"/>	<input type="checkbox"/>	
Is bearing operating temperature excessive?	<input type="checkbox"/>	<input type="checkbox"/>	<input type="checkbox"/>	

White - Customer's Copy

Canary - Fairbanks Nijhuis Representative's Copy

Pink - Fairbanks Nijhuis Field Service Copy

Customer's Representative
Witnessing Start-Up

Date _____

Company _____

Name _____

Fairbanks Nijhuis
Representative Conducting Start-Up

Date _____

Name _____

Table of Contents

WARRANTY	i	DISASSEMBLY OF THE PUMP	17
WARRANTY HIGHLIGHTS	i	PACKING	17
WARRANTY	ii	MECHANICAL SEALS	19
START-UP CHECK LIST	iii	REASSEMBLY	20
INTRODUCTION	1	STANDARD PACKING	21
GENERAL	1	MECHANICAL SEALS	21
CAUTION & SAFETY NOTICE	1	STARTING PUMP AFTER REASSEMBLY	22
PUMP IDENTIFICATION	2	HISTORY	24
SAFETY NOTES	2	NOTES	25
HOUSEKEEPING	2	REPAIRS	26
ENVIRONMENTAL CONDITIONS	3	ORDERING PARTS	26
STORAGE OF PUMPS	3	RECOMMENDED SPARE PARTS	26
GENERAL	3	RETURNING PARTS	26
CONSIDER A UNIT IN STORAGE:	3	SERVICE	26
SHORT-TERM STORAGE	3	WARRANTY SERVICE:	26
LONG-TERM STORAGE	3	SERVICE AFTER WARRANTY	26
THREE MONTHS TO ONE YEAR	3	PREDICTED LIFE	26
OVER ONE YEAR	4	PARTS LIST	27
REMOVING FROM STORAGE	4	ASSEMBLY DRAWING	
INSTALLATION	6		
NET POSITIVE SUCTION HEAD (NPSH)	6		
WET WELL DESIGN	6		
LOCATION AND HANDLING	6		
FOUNDATION	7		
LEVELING OF THE UNIT	7		
GROUTING	7		
PIPING	7		
FINAL COUPLING ALIGNMENT	8		
PERIODIC CHECK	8		
AUXILIARY PIPING CONNECTIONS	8		
ROTATION	8		
OPERATION	9		
GENERAL	9		
OPERATING AT REDUCED CAPACITY	9		
PRIMING	9		
STARTING THE PUMP	10		
NORMAL OPERATION	10		
STOPPING THE PUMP	10		
NORMAL SHUTDOWN	10		
EMERGENCY SHUTDOWN	10		
BEARING OPERATING TEMPERATURE	10		
TROUBLESHOOTING	11		
PUMP	11		
MOTOR	14		
SERVICE	16		
LUBRICATION OF BEARINGS	16		
REPAIRS	17		

INTRODUCTION

CALIFORNIA PROPOSITION 65 WARNING: WARNING:

This product and related accessories contain chemicals known to the State of California to cause cancer, birth defects or other reproductive harm.

GENERAL

Congratulations! You are the owner of the finest pump commercially available. If you give it the proper care as outlined and recommended by this manual, it will provide you with reliable service and long life.

This manual contains information which is the result of engineering and research efforts. It is designed to supply adequate instructions for the installation, operation and maintenance of your pump. Failure or neglect to properly install, operate or maintain your pump may result in personal injury, property damage or unnecessary damage to the pump.

These instructions apply to the pump only and have been prepared specifically for the pump supplied on this order. If your operating conditions ever change, always refer to the factory for reapplication. Always refer to the manuals provided by manufacturers of the accessory equipment for their separate instructions.

Variations exist in both the equipment used with these pumps and in the particular installation of the pump and driver. Therefore, specific operating instructions are not within the scope of this manual but should be added by the parties responsible for the operation of the entire station. The manual contains general rules & guidelines for installation, operation and maintenance of the pump. If there are questions regarding the pump or its application which are not covered in this manual, please contact the factory as follows:

Fairbanks Nijhuis™
3601 Fairbanks Ave.
Kansas City, KS 66106
(913) 371-5000

For information or technical assistance on the drive source, contact the drive manufacturer local dealer or representative.

To obtain additional data on hydraulics and pump selection and operation, we suggest you purchase both of the following reference books:

- A. Fairbanks Nijhuis "Hydraulic Handbook" available from the factory.
- B. Hydraulic Institute Standards
Hydraulic Institute
9 Sylvan Way
Parsippany, NJ 07054-3802

CAUTION & SAFETY NOTICE

The installation, use and operation of this type of equipment is affected by various federal, state and local laws and the regulations concerning OSHA. Compliance with such laws relating to the proper installation and safe operation of this type of equipment is the responsibility of the equipment owner and all necessary steps should be taken by the owner to assure compliance with such laws before operating the equipment. In addition **WARNING** and **CAUTION** notes are located throughout this manual. They should be read and observed.

The following symbols are used to alert maintenance personnel to procedures which require special attention, or which could damage equipment or could be dangerous to personnel.

DANGER

- **Indicates an imminently hazardous situation which, if not avoided, will result in death or serious injury.**

WARNING

- **Indicates a potentially hazardous situation which, if not avoided, could result in serious injury.**

CAUTION

Indicates that improper practices will result in equipment malfunction or failure.

NOTES

- **Instructions which will aid in installation, operation, maintenance or which clarify a procedure.**

PUMP IDENTIFICATION

Pertinent nameplate information is shown below. It will aid in obtaining the correct replacement parts for your pump. The serial number is stamped on the discharge flange.

Pump	
Serial Number	
Model Number	
Pump Size	
Number Stages	
GPM	
Head (feet)	
Speed (RPM)	
Driver	
Manufacturer	
Horsepower	
Serial Number *	
Full Load Amps	
Phase/Hz/Volts	

*To Be copied from Motor nameplate

SAFETY NOTES

These warnings apply to pumps supplied by Fairbanks Nijhuis™. Refer to the manuals supplied by the driver or control manufacturers for additional warnings before operating this equipment.

Before attempting to service this pump:
 Familiarize yourself with this manual.

DANGER

- **Disconnect or lock out the power source to ensure the pump will not start. Check with appropriate electrical test equipment.**
- **Do not attempt to service the pump until the electrical power has been disconnected and it has been verified that the pump cannot start.**

WARNING

- **Certain procedures in disassembly and assembly require parts be heated to high temperatures. Heat resistant gloves must be worn when handling heated parts. Heated parts can cause severe personal injury.**

CAUTION

After the pump has been installed make certain that the pump and all piping connections are tight and are properly supported prior to start-up and operation.

WARNING

- **Do not operate the pump without the protective guards in place over the rotating parts. Exposed rotating parts can catch clothing, fingers, or tools, causing severe injury to personnel.**

CAUTION

- **This pump is designed for the exclusive use of pumping water. It should not be used for pumping other media unless a specific Purchase/Buyer agreement is negotiated.**

WARNING

- **Because many installations utilize automatic starting equipment the pump unit may start at any time without warning.**

HOUSEKEEPING

The area surrounding the pump installation area should be kept free of rags and debris. The area should be kept clean and dry and should be checked periodically to ensure there is no water, oil or grease on the floor which could cause accidental slippage of maintenance personnel.

The pump & driver should be kept clean. Any spillage of lubricants on the

pump/driver during periodic maintenance should be wiped clean. Loose ends of packing should be picked up and properly discarded after repacking the pump.

Drain lines should be checked to ensure they are functioning properly.

Driver ventilation ports should be kept free to ensure proper cooling of the motor.

ENVIRONMENTAL CONDITIONS

Pumps are designed to operate in moderate to severe environmental conditions. Normally they should not be operated in an ambient temperature exceeding 130° F or in conditions that would allow the sealing water or the pumped media to freeze.

STORAGE OF PUMPS

GENERAL

If the equipment is not to be immediately installed and operated, store it in a clean, dry, well-ventilated place, free from vibrations, moisture and rapid or wide variations in temperature.

Improper storage and preservation could damage the equipment which would result in non-warranty covered restoration requirements or non-warranty covered product failures.

CONSIDER A UNIT IN STORAGE:

1. When it has been delivered to the job site and is awaiting installation.
2. When it has been installed but operation is delayed pending completion of construction.
3. When there are long (30 days or more) periods between operation cycles.
4. When the pump is shut down for periods of longer than 30 days.

SHORT-TERM STORAGE

Short term storage is when the pump will be stored for periods not exceeding three

months. The following are the short-term storage requirements:

- A. Rotate the shaft for several revolutions at least once every two weeks to:
 1. Coat the bearing with lubricant.
 2. Retard oxidation or corrosion.
 3. Prevent possible false brinelling.

LONG-TERM STORAGE

Long-term storage is when the pump will be stored for periods exceeding three months. The following are long-term storage requirements:

THREE MONTHS TO ONE YEAR

1. Remove gland halves, packing and seal water ring from the stuffing box. Package them in a suitable container to prevent loss or damage. Coat the inside of the stuffing box with grease.
 - **If the pump is equipped with a mechanical seal, remove the pipe plug in the stuffing box and pour at least 4 ounces of mineral oil into the seal housing. Reinstall the pipe plug.**
2. Fill the bearing housings with specified lubricating grease until grease exits from relief fittings.
3. Wipe clean all exposed machined surfaces and coat with a heavy layer of grease, or other equivalent rust prevention material.
4. Cover the suction and discharge of the pump with cardboard or wood to prevent entry of foreign material or varmints.
5. Rotate the pump shaft several times by hand repeating this every two (2) weeks during storage. Rotation of the shaft will coat the bearings and retard oxidation, preventing possible false brinelling.

OVER ONE YEAR

1. Remove gland halves, packing and seal water ring from the stuffing box. Package them in a suitable container to prevent loss or damage. Coat the inside of the stuffing box with grease.
- **If the pump is equipped with a mechanical seal, remove the pipe plug in the stuffing box and pour at least 4 ounces of mineral oil into the seal housing. Reinstall the pipe plug.**
2. Fill the bearing housings with specified lubricating grease until grease exits from relief fittings.
3. Clean all accessible machined surfaces to remove dirt, corrosion, grease and any other foreign matter. Clean water passages to remove all foreign matter. Dry the pump to remove all moisture.
4. Spray flushing water and seal water piping with P-7 medium preservative oil. Seal all water inlet connections with pipe caps or plugs.
5. All internal surfaces in contact with water should be sprayed with Grade 5 of MIL-C-15173 Corrosion Preventive Compound, solvent cut back. Drain all excess compound by removing drain plugs. Treat the drain plugs with P-1 or P-19 preservative, replace and tighten.
6. Apply P-2 preservative to all exposed shaft surfaces.
7. Cover inlet and outlet nozzles with Grade A of MIL-B-121 barrier material and a blank flange of mild steel (1/16" minimum thickness), tempered hard board (1/4" minimum thickness) or fully water-proofed plywood (1/4" minimum thickness). Secure the flanges with at least 4 bolts with lockwashers.

8. Wrap the shaft, the frame and the stuffing box area with grease-proof barrier material, conforming to Type I, Grade A of MIL-B-121. Secure the barrier with water-proof pressure sensitive tape.
9. Rotate the pump shaft several times by hand repeating this every two (2) weeks during storage. Rotation of the shaft will coat the bearings and retard oxidation, preventing possible false brinelling.

REMOVING FROM STORAGE

After the storage period is over and prior to operating the pump, remove the cover on the thrust bearing housing for inspection of the bearing lubricant. If any water or foreign matter is found in the lubricant, all bearings must be cleaned and the lubricant replaced.

Refer to the Installation section of this manual for installation instructions.

After the pump has been set and grouted in place, and is ready for operation, the following steps should be followed:

1. Reinstall the packing, seal water ring and gland. Adjust in accordance with this manual. Flush the mineral oil out of the mechanical seal if unit is so equipped.
2. Remove bearing housing covers and remove one-half of the grease in bearing housings. Remove all grease relief fittings and grease relief nipples from upper and lower bearing housings.
3. Start the pump per start-up instructions and permit grease to be purged from each bearing housing. Do not install grease relief piping until purging has completely stopped after the pump has been operation for at least eight (8) hours. Observe bearing temperatures, and stop and start the pump or run it at reduced speed until

temperatures stabilize within the specified limits.

4. Stop the pump, wipe any grease off the shaft and bearing frame and place the pump in service per instructions in this manual.

DANGER

- **Do not attempt to clean the pump until electrical power has been disconnected and it has been verified that the pump cannot start.**

INSTALLATION

Carefully read all sections of this manual and all other instruction manuals provided by manufacturers of other equipment supplied with this pump.

Upon receipt of the shipment, unpack and inspect the pump and driver assemblies and individual parts to insure none are missing or damaged. Carefully inspect all boxes and packing material for loose parts to insure none are missing or damaged. Carefully inspect all boxes and packing material for loose parts before discarding them. Report immediately to the factory, and to the transportation company involved, any missing parts or damage incurred during shipment, and file your "damaged and/or lost in shipment" claim with the carrier immediately.

NET POSITIVE SUCTION HEAD (NPSH)

NPSH can be defined as the head (energy) that causes liquid to flow through the suction pipe and enter the eye of the impeller.

NPSH is expressed in two values:

1. NPSH required (NPSHR)
2. NPSH available (NPSHA)

It is essential that NPSHA always be greater than NPSHR to prevent cavitation, vibration, wear and unstable operation.

NPSHR is a function of the pump design and therefore varies with the make, size, capacity and speed of the pump. The value for your pump can be obtained from your pump performance curve or the factory.

NPSHA is a function of your system and may be calculated as follows:

A. When the source of liquid is above the pump:

1. $NPSHA = \text{barometric pressure (feet)} + \text{static suction head (feet)}^* - \text{friction losses in suction piping (feet)} - \text{vapor pressure of liquid (feet)}$

B. When the source of liquid is below the pump:

1. $NPSHA = \text{barometric pressure (feet)} - \text{static suction lift (feet)}^* - \text{friction losses in suction piping (feet)} - \text{vapor pressure of liquid (feet)}$

*The datum elevation plane for horizontal pumps is the pump centerline.

WET WELL DESIGN

Generally, it is required that an evenly distributed flow of non-aerated water be supplied to the pump suction. Improper wet well or sump design or insufficient suction pipe submergence can result in intake vortexing which reduces the pump's performance and can cause severe damage to the pump.

We recommend that you secure the advice of a qualified Consulting Engineer for the analysis and design of the wet well. Significant engineering data on wet well design is provided in the Hydraulic Institute Standards.

Upon request, Fairbanks Nijhuis™ will review plans and give general comments on the installation, but will not approve such plans for a specific installation and will accept no responsibility or liability for the performance of the pump intake structure.

LOCATION AND HANDLING

The pump should be installed as near the fluid as possible so a short direct suction pipe can be used to keep suction losses at a minimum. If possible, locate the pump so the fluid will flow to the suction opening by gravity. The discharge piping should be direct and with as few elbows and fittings as possible. The total net positive suction head available (NPSHA), which includes the suction lift and pipe friction losses, must be greater than the net positive suction head required (NPSHR) by the pump.

The pump and driver should be located in an area that will permit periodic inspection and

maintenance. Head and access room should be provided and all units should be installed in a dry location with adequate drainage.

WARNING

- **Do not pick up the complete unit by the driver eye bolts or pump shaft.**

FOUNDATION

The pump foundation should have a level surface and be of sufficient mass to prevent vibration and form a permanent rigid support for the unit. The most satisfactory foundations are concrete with anchor bolts of adequate size imbedded in the foundation in pipe sleeves with an inside diameter 2-1/2 times larger than the bolt diameter. This will allow for final accurate positioning of the unit.

Recommended anchor bolt design is available from the factory.

LEVELING OF THE UNIT

Lower the unit onto the foundation and position the base so the anchor bolts are aligned in the middle of the holes in the base. Disconnect the coupling halves and do not reconnect until all alignment operations are complete.

Set the base on metal shims or metal wedges placed directly under the part of the base carrying the greatest weight, and spaced close enough to give uniform support and stability.

Adjust the metal shims or wedges until the shaft of the pump and driver are level or vertical as appropriate and until pump and driver shaft are aligned with each other. Make sure that all shims or wedges fit firmly between the foundation and the base.

If leveling nuts are installed on the anchor bolts and are used for alignment, follow the same procedure as with shims or wedges. Support the base with additional shims or wedges if necessary. Make sure that all nuts and shims are in firm contact with the base.

Tighten the foundation bolts snugly, but not too firmly, and recheck the shafts for alignment before grouting.

GROUTING

When the alignment is correct, the unit should be grouted using a high grade non-shrinking grout. The base is designed to be completely filled with grout.

CAUTION

- **Damaging vibration may result if the base plate is not solidly in contact with the grout bed**

Do not fill the pipe sleeves with grout.

If leveling nuts are used, make sure they are not imbedded in grout. Provide access in the grout to the leveling nuts so that they can be backed off after the grout has cured.

Allow the grout to fully cure before backing off the leveling nuts (if used) and firmly tightening the foundation bolts. Then recheck the alignment before connecting the piping as even the highest quality non-shrink grouts contract slightly during drying.

PIPING

IMPORTANT

- **All piping connections must be made with the pipe in a free supported state, and without the need to apply vertical or side pressure to obtain alignment of the piping with pump flange.**

All piping should be independently supported near the pump so that pipe strain will not be transmitted to the pump casing. The weight of the piping and of the contained liquid must be considered in support design. The suction and discharge piping should be one or two sizes larger than the pump flange sizes, especially where the piping is of considerable length. Any flexible joints installed in the piping must be equipped with tension rods to absorb piping axial thrust.

The suction pipe must be air tight and sloped upward to the pump flange to avoid air pockets which will impair satisfactory pump operation. The discharge pipe should be as direct as possible with a minimum of valves to reduce pipe friction losses.

A check valve and closing valve should be installed in the discharge line and a closing valve in the suction line. The check valve, between the pump and closing valve, protects the pump from water hammer and prevents reverse rotation in the event of power failure. The closing valves are used in priming, starting and when the pump is shut down. The pump must never be throttled by the use of a valve in the suction line.

FINAL COUPLING ALIGNMENT

Check safety codes, and always install protective guard or shield as required by the various federal, state and local laws and the regulations concerning OSHA.

The final coupling alignment must be made after the piping has been connected. If realignment is required, disconnect the piping first then proceed with the alignment. Reconnect the piping after alignment has been completed, and check the alignment before connecting the coupling.

A flexible coupling must not be used to compensate for misalignment resulting from poor installation or temperature changes.

Fairbanks Nijhuis™ pumps are supplied with several different types of commercial couplings. Refer to the instruction sheet, which can be found in **Section 8** of this manual. It should be thoroughly studied before proceeding.

PERIODIC CHECK

Coupling misalignment can occur because of shifts in grouting, foundation or because of large objects going through the pump causing shock loading conditions.

Coupling alignment should be checked periodically for changes. Coupling misalignment can lead to or cause bearing failure, coupling failure, shaft breakage, high power consumption. etc.

Refer to the coupling installation instructions supplied with this O&M for alignment tolerances.

AUXILIARY PIPING CONNECTIONS

Install any additional piping connections, your pump may require such as water seal piping, stuffing box drain, baseplate drain, and pressure gauges.

NOTE

- **For satisfactory pump operation and life, these auxiliary pipe lines must be kept clean.**

ROTATION

Before connecting the motor to the pump, bump start the driver and verify rotation is in the proper direction. The correct pump rotation is indicated by a directional arrow on the pump casing.

OPERATION

GENERAL

This section contains general rules for operation. Because variations may exist in a particular installation between the pumps, the drivers and the accessory equipment, specific operating instructions are not within the scope of this manual.

WARNING

- **Before starting or operating the pump, read this entire manual and especially comply with the following instructions:**
 - A. Before starting the pump, install guards around all exposed rotating parts.
 - B. Before starting the pump, rotate the unit or assembly by hand to assure all moving parts are free.
 - C. Observe all caution or danger tags attached to the equipment.
 - D. Never run the pump dry as the close running fits within the pump are lubricated by the liquid. running dry may result in pump seizure.
 - E. Before starting the pump, fill the casing and suction line with liquid, the pump may be primed by using a priming system.
 - F. If excessive vibration or noise occurs during operation, shut the pump down and consult a Fairbanks Nijhuis™ representative.
 - G. Before starting a packed box pump, adjust the packing so there is sufficient leakage to lubricate the packing and assure a cool stuffing box. (See maintenance instructions)

OPERATING AT REDUCED CAPACITY

In a typical application covering a wide range of flow rates, a variable speed driver is often used to adjust pump capacity, and this is

taken into consideration by Fairbanks Nijhuis when selecting the pump and impeller trim. Although these pumps are applicable over a wide range of operating conditions, care should be exercised when doing so, especially when the actual conditions differ from the sold for conditions. You should always contact your nearest Fairbanks Nijhuis distributor or factory before operating the pumps at any condition other than that for which they were sold.

Generally, these pumps can be operated continuously at a capacity equal to 25% of the pump capacity at the best efficiency point, and at higher capacities. At capacities less than 25% of best efficiency point capacity, we recommend that the pumps be operated for intermittent periods of time only.

PRIMING

The priming procedure is different for positive and negative suction head systems and the following procedures should be followed:

- A. Positive suction head
 1. Open the vent on the highest point on the pump casing.
 2. Open all suction valves.
 3. Allow the liquid to flow from the vent hole until all air bubbles are vented, and then close the vent.
 4. The pump is now primed.
- B. Negative suction head
 1. Install the priming system on the vent on the highest point of the, pump casing.
 2. Close the discharge valve.
 3. Open the suction valve.
 4. Start the priming system.
 5. Run the priming system until a continuous stream flows through the suction line, then close the valve to the vent.

6. The pump is now primed.

STARTING THE PUMP

- A. After the pump is primed, and with the discharge valve closed and the suction valve open, start the driver according to the driver manufacturer's instructions.
- B. Open the discharge valve slowly to prevent water hammer.
- C. Immediately after the pump has been started, check bearing temperature, stuffing box lubrication and operation, and pump noise level. Continue to monitor these values for the first several hours of operation.

NORMAL OPERATION

Monitor the following during running cycles:

- A. Unit vibration or noise.
- B. Driver lubrication.
- C. Pump lubrication.
- D. Packing box leakage.

Check the following before normal startup:

- A. Driver lubrication.
- B. General condition of all equipment.

Startup after a week or more down time.

- A. Repeat those procedures covered by initial startup.

STOPPING THE PUMP

Pump stations are usually designed to have the pumps started and stopped automatically using a controller. Since this is a function of station design, the operators should be thoroughly familiar with the systems operating parameters and in the use of the controller. The general procedure to shut down the pump is as follows:

NORMAL SHUTDOWN

- A. Disconnect the electrical power.
 - 1. Lock out the power to the driver.

DANGER

- Check power source with appropriate electrical test equipment to ensure driver cannot accidentally start.
- B. If the pump is to be removed for repair, close the suction and discharge valves.

EMERGENCY SHUTDOWN

In the event of an emergency, shut off the power at the nearest switch. The operator or persons working around the equipment should be familiar with locations of emergency shut off points.

Many installations are equipped with emergency shut off switches near the pump location. These locations should be plainly marked and be readily accessible at all times.

The control panel (if used) may be equipped with an emergency stop button or switch.

BEARING OPERATING TEMPERATURE

These pumps are designed to operate over a wide ambient temperature. The temperature, when measured on the outside surface of the bearing housing, should not exceed 190°F. Temperatures in excess of 190°F may indicate a lack of lubricant, or bearing problems. If the temperature exceeds this limit, the pump should be stopped and the cause investigated and corrected.

TROUBLESHOOTING**PUMP**

Your Fairbanks Nijhuis™ pump has been engineered and carefully selected for your application. It should provide years of trouble-free service. However, any piece of machinery is subject to wear and occasional malfunction.

To help you quickly isolate and rectify any malfunction, the following troubleshooting guide has been prepared.

Frequent use of the chart to determine the cause of minor operating problems may prevent a major problem or possible breakdown of your pump.

TROUBLE	PROBABLE CAUSE	REMEDY
1. Pump fails to prime or loses its prime	a. Air leaks in suction lines	a. Clean and tighten all suction connections; relocate suction inlet in liquid source.
	b. Suction strainer is clogged	b. Remove dirt, leaves, or other material from the strainer.
	c. Suction lift is too high	c. Re-evaluate pump requirements and correct suction conditions.
	d. Defective priming valve	d. Replace valve.
	e. Defective packing or seal	e. Replace packing or seal.
2. No discharge from pump	a. Pump is not properly primed	a. Reprime the pump; refer to priming troubles and remedies
	b. Total head is too high	b. Re-evaluate head calculations; measure elevation differences between pump and liquid source and pump discharge point. Consult your local Fairbanks Nijhuis™ sales office.
	c. Driver is not operating at rated speed	c. Check voltage of electric motor; check steam pressure of steam turbine; check engine rpm's. Refer to appropriate maintenance manuals for possible troubles and corrective action.
	d. Impeller or discharge line is clogged	d. Back flush pump to clear obstruction; disassemble pump and/or piping and remove obstruction.
	e. Wrong direction of rotation	e. Check wiring against diagram motor nameplate and in controller; reverse any two power leads on a three phase motor; replace a single phase motor.
	f. Pump is vapor bound	f. Provide additional pressure on liquid being pumped by elevating liquid source or pressurizing the supply tank.

3. Pump does not deliver rated capacity.	a. Pump is not properly primed	a. See 2.a
	b. Suction lift is too high	b. See 1.c
	c. Excessive air in liquid	c. See 1.a
	d. Air leakage thru stuffing box	d. See 1.e
	e. Driver is not operating at rated speed	e. See 2.c
	f. Impeller is clogged	f. See 2.d
	g. Wearing rings are worn	g. Replace wearing rings
	h. Impeller is damaged	h. Replace impeller
	i. Pump is vapor bound	i. See 2.f
4. Insufficient Pressure	a. Excessive air in liquid	a. See 3.c
	b. Drive is not operating at rated speed	b. See 2.c
	c. Wrong direction of rotation	c. See 2.e
	d. Total head is too high	d. See 2.b
	e. Wearing rings are worn	e. See 3.g
	f. Impeller is damaged	f. See 3h
	g. Casing gasket defective allowing internal leakage	g. Replace casing gasket
	h. Liquid is vaporizing	h. See 2.f
5. Pump starts then stops pumping	a. Air leaks in suction line	a. See 1.a
	b. Air pockets in suction line	b. Reprime the pump; eliminate air pockets
	c. Water seal line is plugged	c. Remove obstruction from water line
	d. Excessive air in liquid	d. See 1.a
	e. Suction lift too high	e. See 1.c
	f. Defective packing or seal	f. See 1.e
	g. Pump is vapor bound	g. See 2.f
6. Excessive power consumption	a. Speed is too high	a. Internal electric motor wiring is incorrect; replace motor; refer to applicable driver maintenance manuals for possible troubles and corrective action
	b. Wrong direction of rotation	b. See 2.e
	c. Total head is too high	c. See 2.b
	d. Total head is too low	d. Re-evaluate head conditions; correct as required. Consult your Fairbanks Nijhuis™ sales office.
	e. Impeller is clogged	e. See 2.d
	f. Impeller is binding	f. Relieve strain on casing; adjust impeller clearance
	g. Motor shaft is bent or worn	g. Replace motor shaft
	h. Drive and pump are misaligned	h. Realign driver with pump
	i. Power frame shaft is bent or worn	i. Replace shaft
	j. Wearing rings are worn	j. See 3.g
	k. Packing is incorrectly installed	k. Install packing correctly

7. Pump is noisy or has excessive vibration	a. Magnetic Hum	a. Consult motor manufacturer
	b. Motor bearings are worn	b. Replace b bearings
	c. Foreign material in impeller	c. Remove foreign material
	d. Impeller is binding	d. See 6.f
	e. Motor shaft is bent or worn	e. See 6.g
	f. Drive and pump are misaligned	f. See 6.h
	g. Power frame shaft is bent	g. See 6.i
	h. Foundation is not rigid	h. Strengthen foundation; change method of mounting pump unit
	i. Worn bearing in power frame	i. Replace bearing
	j. Impeller is damaged	j. See 3.h
	k. Lack of lubrication in power frame	k. Lubricate power frame bearing; replace bearings if damaged
	l. Pump is not properly leveled	l. Check levelness of pump
	m. Piping is not supported	m. Provide support for suction and discharge piping
	n. Pump is cavitating	n. Re-evaluate pump application; consult local Fairbanks Nijhuis™ sales office.

MOTOR

The trouble or symptoms, their probable causes and the suggested remedies contained in this troubleshooting guide will assist you in quickly determining and correcting most problems should they occur. It is not the intention of Fairbanks Nijhuis™ to replace the recommendations of the motor manufacturer in regard to operation and maintenance. Rather, this guide is offered as a supplement to such data. Any specific questions or problems should be directed to the manufacturer of the motor. Be sure to supply the relevant data

from the motor nameplate when inquiring about motor service or maintenance.



- **Electrical trouble shooting should be performed by qualified electricians skilled in the use of electrical instruments.**

Electrical power should be disconnected and locked to prevent the motor from accidentally starting during mechanical systems check.

TROUBLE	PROBABLE CAUSE	REMEDY
1. Motor does not start	a. Break in power supply circuit <ol style="list-style-type: none"> 1. Blown or defective primary fuses or open circuit breakers 2. Blown or defective secondary fuses or opened circuit breakers b. Open control circuit <ol style="list-style-type: none"> 1. Overload trips are open 2. Defective holding coil in magnetic switch 3. Loose or poor connections in control circuit c. Magnetic switch closes <ol style="list-style-type: none"> 1. Poor switch contact 2. Open circuit in control panel 3. Open circuits in leads to motor 4. Leads improperly connected 	a. Close break in circuit <ol style="list-style-type: none"> 1. Check voltage across all phases above the disconnect switch. Replace fuses or reset circuit breakers as necessary 2. Check voltage across all phases below disconnect switch (with disconnect switch closed). Replace fuses or reset circuit breakers as necessary. b. Complete control circuit <ol style="list-style-type: none"> 1. Push reset button 2. Push start button and allow sufficient time for operation of time delay, if used, then check voltage across magnetic holding coil. If voltage is measured, coil is defective. If no voltage is measured, control circuit is open. 3. Make visual inspection of all connections and re-tighten as necessary c. Check switch operation <ol style="list-style-type: none"> 1. Open manual disconnect switch, close magnetic switch by hand and examine contractors and springs 2. Check voltage at T1-T2-T3 3. Check voltage at leads to outlet box 4. Check lead numbers and connections

2. Motor fails to come up to speed	<ul style="list-style-type: none"> a. Low or Incorrect voltage b. Incorrect connections at motor c. Overload-Mechanical d. Overload-Hydraulic 	<ul style="list-style-type: none"> a. Check voltage at T1-T2-T3 in control panel b. Check for proper lead connections at motor, compare with connection diagram on motor. c. Check impeller setting. Check for tight or locked shaft d. Check impeller setting. Check GPM against pump capacity and head
3. Motor runs hot	<ul style="list-style-type: none"> a. Inadequate ventilation b. Overload c. Unbalanced supply voltage 	<ul style="list-style-type: none"> a. Assure adequate supply of fresh air. Check air blast through motor by feeling air discharge at bottom of motor b. Check load with ammeter d. Check supply voltage with volt meter
4. Motor vibrates	<ul style="list-style-type: none"> a. Headshaft misaligned b. Worn shaft bearings or bent shaft c. Hydraulic disturbance in discharge piping d. Unbalanced rotor assembly e. Motor not mounted securely 	<ul style="list-style-type: none"> a. Remove top drive coupling and check alignment of motor to pump. b. Disconnect motor from pump and run motor only to determine source of vibration. c. Check isolation joint in discharge piping near pump head. d. Balance rotor e. Secure properly and check alignment
5. Motor noisy	<ul style="list-style-type: none"> a. Worn thrust bearing b. Electrical noise 	<ul style="list-style-type: none"> a. Remove dust cover, rotate rotor by hand and make visual inspection of balls and races. (Bearing noise is usually accompanied by high frequency vibration) b. Most electrical motors are electric noisy during the starting period. The noise should diminish as the motor reaches full speed.
6. Incorrect rotation	<ul style="list-style-type: none"> a. Incorrect connections 	<ul style="list-style-type: none"> a. Refer to connection diagram and re-connect according to instructions

SERVICE

Your Fairbanks Nijhuis™ pump requires no maintenance other than periodic inspection, lubrication and occasional cleaning. The intent of inspection is to prevent breakdown, thus obtaining optimum service life.

LUBRICATION OF BEARINGS

DANGER

- **Break electrical connections to motor or take other steps needed to prevent drive unit from being unintentionally energized during lubrication.**

DANGER

- **Check with appropriate electrical test equipment to ensure the power is disconnected.**

Regreasable bearings will require periodic lubrication and can be accomplished by using the zerk or lubrication fittings in the bearing cartridge. Lubricate the bearings at regular intervals using a grease of high quality. Lithium, lithium soda or calcium base grease is recommended as lubricants for pumps operating in both wet and dry locations. Mixing of different brands of grease should be avoided due to possible chemical reactions between the brands which could damage the bearings. Accordingly, avoid grease of vegetable or animal base which can develop acids, as well as grease containing rosin, graphite, talc and other impurities. Under no circumstances should grease be reused.

Over lubrication should be avoided as it may result in overheating and possible bearing failure. Under normal application, adequate lubrication is assured if the amount of grease is maintained at 1/3 to 1/2 the capacity of the bearing and adjacent space surrounding it.

In dry locations, each bearing will need lubrication at least every 4,000 hours of running time or every 6 to 12 months, whichever is

more frequent. In wet locations the bearings should be lubricated at least after every 2,000 hours of running time or every 4 to 6 months, whichever is more frequent. A unit is considered to be installed in a wet location if the pump and motor are exposed to dripping water, to the weather, or to heavy condensation such as is found in unheated and poorly ventilated underground locations.

At times it may be necessary to clean the bearings due to accumulated dirt or deteriorated lubricants. This can be accomplished by flushing the bearing with a light oil heated to 180 to 200°F. While rotating it on a spindle, wipe the bearing housing with a clean rag soaked in a cleaning solvent and flush all surfaces.

Dry bearing thoroughly before relubricating. Compressed air can be used to speed drying, but care should be taken not to let bearings rotate while being dried.

DANGER

- **Use normal fire caution procedures when using any petroleum cleaner.**

Model 1820 Pumps are available with two options for lubricating the shaft bearings. They are:

1. Regreasable (standard)
2. Oil Lubrication

Model 1820F pumps are available with grease lubricated bearings only.

Oil lubricated bearings are optional on Model 1820 pumps. A fixed oil level is maintained within the bearing cartridge by an oiler which allows visual indications of reserve oil.

At initial installation and before starting a unit that has been shut down for repairs or for any extended length of time, run enough 10W-30 weight motor oil through the oiler to maintain a constant oil level to insure that the bearing will never be without an oil supply.

Oil will have to be added at intervals to maintain a constant level in the oiler. This interval can only be determined by experience.

Under working conditions, oil will break-down and need to be replaced at regular intervals. The length of these intervals will depend on many factors. Under normal operation, in clean and dry locations, the oil should be changed about once a year. However, when the pump is exposed to dirt contamination, high temperatures (200°F. or above) or a wet location, the oil may have to be changed every 2 or 3 months.

The motor that drives your Fairbanks Nijhuis™ pump may or may not require lubrication. Consult the manufacturer's recommendations for proper maintenance instructions.

REPAIRS

The pump may be disassembled using the illustrations and text provided. Although complete disassembly is covered, it will seldom be necessary to completely disassemble your Fairbanks Nijhuis pump.

An assembly drawing is included in the back of this manual for your reference.

Inspect removed parts at disassembly to determine their reusability. Cracked castings should never be reused. All packing and gaskets should be replaced with new ones at reassembly simply as a matter of economy; they are much less expensive to replace routinely than to replace as the need occurs. In general it is economical to return to the manufacturer for repair only the motor and motor controller.

DISASSEMBLY OF THE PUMP.

Disassemble only what is needed to make repairs or accomplish inspection. Proceed to disassemble the pump as follows: (Refer to the assembly drawing included in this manual).

PACKING

WARNING

- **The use of a suitable,adequately sized,lifting device will be required throughout the disassembly process.**
1. **Break electrical connections to motor or take other steps needed to prevent drive unit from being unintentionally energized during disassembly.**

DANGER

- **Check with appropriate electrical test equipment to ensure the power is disconnected.**
2. Close such valves or flow-control devices necessary to make certain flow of liquid will not take place during disassembly.

NOTE

- **Discharge and suction piping need not be disturbed unless complete pump assembly is to be removed.**
3. Drain liquid from pump by removing the drain plugs. Disconnect any flushing, cooling, by-pass lines that are connected to parts that will be removed.
 4. Loosen and remove capscrews securing casing halve to remainder of pump assembly.

NOTE

- **If pump being disassembled is size 4 x 5 x 11 or larger, remove capscrews also before attempting to separate casing halves.**
5. Make certain all securing capscrews are removed, then carefully remove casing halve (3) using hoist or crane with a sling attached around cast hooks on the casing and under the casing.

WARNING

- **Use extreme care when casing comes loose that it does not drop out of sling as this would cause extensive damage to other components of pump.**
6. Remove gasket (157) and scrape mating surfaces of casing halves(2,3) to remove pieces of gasket which have adhered in separation. Take care not to scratch or mar mating surfaces.
 7. Loosen flexible coupling and slide the halves apart.
 8. Remove four capscrews securing two bearing caps (6). Lift off bearing caps (6) and pins. Mark caps to insure correct replacement and orientation on the respective bearing arms.
 9. Loosen and remove four nuts, washers , and gland clamps securing split halves of two packing glands (19). Remove four swing bolts.
 10. Assuming that further work is required on shaft (4) and impeller (1) assembly use properly secured rope slings and hoist or crane as required to lift it from casing half (2) and place it on a suitable bench or work surface:

CAUTION

- **Take care not to dent or damage impeller and/or other parts. Use of a supporting cradle or work stand is recommended.**

NOTE

- **Disassembly procedure from this point covers pumps having standard packing. If pump has mechanical seals, refer to specific instructions.**
11. Remove and discard rings of packing (212). Replacement with new packing is

recommended whenever pump is disassembled.

12. Slip off flexible coupling halve and remove key (272). If preferred, the key may be removed by carefully tapping it from outer end with a brass drift or similar non-marring tool, using a small hammer.
13. Remove two casing wearing rings (16).
14. Remove zerks and pipe plugs from cartridge caps (A158, B158).
15. Loosen and remove four capscrews from cartridge cap (A158). The outboard shaft end protector (118) may be removed from its recess in the outboard cartridge cap if necessary. Remove retainer ring (161) with a pair of truarc pliers. Also remove gasket (B20).

NOTE

- **If the unit has a tandem shaft, protector (29) is not used.**
16. Outboard bearing (168) is press fitted onto shaft (4). To remove it, place a puller on bearing cartridge (A158) and pull cartridge, grease seal (159A) and bearing from shaft. The grease seal can be pressed from the bearing cartridge if it needs replacing, then slide slinger (126), lantern ring (10) and bushing (20) off shaft (4).
On 6B and 7 Power Frames remove snap ring (161) on inboard side of bearing. Then slide slinger (126), lantern ring (10), bushing (20) off shaft (4).
 17. Removal of inboard bearing is basically the same as for outboard bearing. Remove capscrews and slide slinger (126), cartridge cap (B158), grease seal (D159A) and gasket (B20) off shaft.

18. Pull or press off bearing cartridge (B158), grease seal (D159A) and bearing (163). Remove slinger (126), lantern ring (10) and bushing (20) from shaft.
19. If pump has right hand rotation, unscrew and remove outboard sleeve (14) first. Remove o-ring (A20). If pump has left hand rotation unscrew and remove inboard sleeve (14) first. Remove o-ring (A20).
20. Key (102) holds impeller (1) and either sleeve (14) if pump is right hand or sleeve (14) for a left hand pump. These parts can be removed by pulling impeller from shaft (65) and removing key (63) from its position in keyway and sleeve. Unscrew and remove remaining sleeve and gasket.
21. Disassemble wearing ring (17) (optional) from impeller (1) only if necessary. On power frames 5,6B and 7, remove set-screws. Apply a puller and gradually withdraw wearing rings (17) from impeller (1). Wearing rings may have to be cut or trimmed off the impeller. If a lathe is used to trim rings off, use care not to clamp impeller too tight and cause distortion. Also use care not to remove any metal from impeller.
22. Remove locking and locating pins from casing halve (2) only if replacement is necessary.
23. Nameplate and its securing screws should only be removed if replacement is necessary.
24. If complete removal of pump is required, disconnect the suction and discharging piping from casing halve (2). Remove nuts from foundation bolts and lift pump out.

MECHANICAL SEALS

1. Perform disassembly procedure as previously given through step 8.
2. Loosen and remove four nuts and washers thus freeing swing bolts to allow shaft (4) and impeller (1) assembly to be lifted from casing halve (2) with sling and hoist or crane as described in paragraph 10 above.
Use extreme care in moving this assembly, because ceramic seats can be cracked by sliding loose on the shaft. To prevent this, wrap seal securely in a cloth to stop it from sliding on shaft.
3. With shaft and impeller assembly, on a suitable bench, cradle, or work stand, loosen and remove pipe plug from inboard cartridge cap (B158). Remove grease zerk and capscrews and slide cartridge cap with grease seal (158B) off end of this shaft (4). Remove gasket (B20).
4. Either pull or press bearing cartridge (B158), grease seal (D159A) and bearing (163) off shaft. Remove slinger (48).
5. The one piece gland (31) used with mechanical seal (456) assembly can now be removed from the shaft.
6. 'O' ring can be removed from seal gland if desired.
7. Exercise great care in removing seal assembly (456) to keep from marring or otherwise damaging precision ground mating surfaces.
8. Scribe a mark on shaft sleeves for relocating seal collar on reassembly. Loosen set-screws securing seal collars to shaft sleeves and slide them off.
9. Proceed with further disassembly of outboard seal assembly using the same procedure.

10. After removal of mechanical seals, proceed with balance of disassembly in same manner- as described for packing design.

REASSEMBLY

Reassembly will generally be in reverse order of disassembly. If disassembly was not complete use only those steps related to your particular repair program.

WARNING

- **The use of a suitable, adequately sized, lifting device will be required throughout the assembly process.**
1. Position locating pins in lower casing (2), adding swing bolt pins, if used on your pump. Install wearing ring pins. Tap pins gently, to seat them in place. If nameplate was removed, install it with screws. Install o-ring (A20) in shaft sleeve (14).
 2. On a right hand unit thread inboard sleeve (14) onto shaft (4) distance A (refer to *Sleeve Adjustment Illustration*). On a left hand unit thread outboard sleeve (14) onto the shaft a distance A (refer to *Sleeve Adjustment Illustration*). When the sleeve is in position its keyway should align with keyway on shaft. Coat key and keyway with Loctite Sealant Grade 242. Insert key (102) into keyways of shaft and sleeve. Tap it firmly in place.
 3. Coat inside diameter of impeller wearing rings (17) (optional) with Loctite sealant Grade 271 and press them over hubs of impeller (1). Do not attempt to hammer impeller wear rings into position, since they are a press fit. Use of an arbor press is preferred. However, placing a block of wood over the impeller wearing ring and pressing it in will work satisfactorily. For power frames 5, 6B and 7 only, two setscrews will be installed by drilling into wearing rings and impeller. The op-

posite surface of the impeller should be protected from damage throughout the procedures by resting it against soft wood on the surface of work bench.

Impeller wearing rings (17) must be given special care because they are press fit. Be sure rings are positioned squarely over the hubs of impeller. A softhearted hammer may be used to gently tap impeller wearing rings into correct alignment before they are pressed into place.

4. Coat impeller (1) keyway, with loctite sealant grade 242 and slide onto shaft until it is firmly, against the shaft sleeve. Place o-ring (A20) in shaft sleeve (14) and thread shaft sleeve firmly, against the impeller.

CAUTION

- **When assembling rotating element of a 1800 Series Pump, it is important that the curve of the impeller blades is in agreement with pump rotation.**

CAUTION

- **Carefully check that proper shaft sleeve has been keyed into place for rotation of pump. If correct shaft sleeve is not keyed onto shaft, it can spin loose during operation of pump and cause excessive damage. Refer to *Sleeve Adjustment Illustration*.**
5. Install packing or mechanical seals and secure according to the following specific instructions.

STANDARD PACKING

- a. Slide a bushing (20) onto each end of shaft. The raised shoulder on these bushings must face away from impeller.
- b. Pump sizes 2 x 2-1/2 x 9, 2 x 2-1/2 x 10 and 2 x 2 1/2 x 12 have one packing ring (212) in front of lantern ring (10). All other pump sizes have two packing rings in front of lantern ring. Stagger the joints in packing rings so pump will not leak excessively.

MECHANICAL SEALS

6. Single Seal and Balanced Single Seals
 - a. Slide one seal lock collar with set-screws facing the impeller onto each end of the shaft. Position on scribe mark made during disassembly and lock in place.
 - b. Put a light coat of liquid dishwashing detergent on the shaft sleeve. Check rotating parts of seal to make sure they are clean. Spread a light coat of liquid detergent on inside diameters of flexible bellows and washers.
 - c. Place the seal's spring, drive ring, retainer, flexible bellows, and washer on the shaft sleeve in respective order.
 - d. Thoroughly inspect cavity of seal gland (31) for burrs or nicks which would damage seat of the seal. Apply a film of liquid detergent to seal seat and install it in seal gland cavity, taking care to seat it evenly and squarely.

NOTE

- **If it is not possible to insert the seat with fingers, place a cardboard protecting ring, furnished with seal, overlapped face of seat and press into place with a piece of tubing having end cut square. Tubing should be slightly larger than the diameter of the shaft.**

Remove cardboard after the seat is firmly in place.

CAUTION

- **Never place a mechanical seal into service after it has been used without replacing or relapsing stationary seat and washer faces.**
 - e. Place "O" rings around the seal glands and slide seal glands onto the ends of the shaft.
7. Double Seal
 - a. Place one seal seat in collar, the other one fits into seal gland (31). These parts are set into their cavities in the same manner as they are with a single seal.
 - b. Place "O" rings around collars and put the collars with stationary seats facing away from impeller on ends of the shaft, then slide flexible bellows, washers, and springs on the shaft (4), for each half of double seal assembly (456).
 - c. Place "O" rings around the seal glands (31) and slide seat glands onto ends of the shaft with stationary seats facing impeller.
 8. Place slinger (126) onto outboard end of the shaft.
 9. Press grease seal (159A) into bearing cartridge (A158). On 6B and 7 Power Frames replace snap ring (161) on inboard side of bearing. Place outboard double row ball bearing (168) in bearing cartridge and press these parts onto outboard end of the shaft. Snap retainer ring (161) in place to secure outboard bearing. Place gasket (B20) and cartridge cap (6) in position and secure with capscrews.
 10. Protector (118) can be placed in the cartridge cap or if unit has a tandem shaft,

press grease seal into cartridge cap and slide a slinger onto shaft.

11. Place slinger (126) on inboard end of the shaft.
12. Press grease seal (D159A) into bearing cartridge (B158). Place the inboard ball bearing (163) in the bearing cartridge and press this assembly onto inboard end of the shaft.
13. Press grease seal (D159A) into cartridge cap (6). Position gasket (B20) and cartridge cap against bearing cartridge and secure it in place with capscrews. Be sure to align grease zerker hole and pipe plug hole to the front.
14. Place slinger (126) onto shaft. Place grease zerks in bearing cartridges and pipe plugs in bearing caps. If pump is oil lubricated, breather tubes are placed in bearing cartridges and oilers with nipples and elbows are placed in cartridge caps.
15. Slide casing wearing rings (16) over impeller wearing rings (17) and set rotating element into casing halve (2). Make certain the holes that are drilled in bottom surface of casing wearing rings locate over pins previously set in casing halve (2). Grease zerks or breather tube should face outward.
16. Install key (272) in motor end of shaft (4). Check positioning and alignment of packing rings or seal components and install swing bolts and split gland halves (19) if the pump has packing. Place in position clamps, washers, and nuts securing loosely in place. Swing bolts are set over pins on 4 x 5 x 10 or smaller pumps. On larger pumps swing bolts are held in place by capscrews after casing halve (2) is in position.

17. Place pins into bearing cartridges. Place bearing caps (6) in position and secure with capscrews.
18. Position new casing gaskets (157) on casing halve (2). Set casing halve (2) in place and secure it to casing halve (3) with capscrews. Pins (158B) are used as a means of locating position of the two casing halves.
19. On pumps larger than 4 x 5 x 10, thread in capscrews making sure they are placed through the eyes of swing bolts.
20. Place drain plugs back in the casing halves.
21. If lower casing was removed from the base, see section on Installation for proper methods of realigning pump to motor and piping.
22. Replace any flushing, cooling, by-pass or drain lines that were removed from the pump. Connect electricity back to the motor.

STARTING PUMP AFTER REASSEMBLY

CAUTION

- **Do not start pump until all air and vapor have been bled and making sure that there is liquid in pump to provide necessary lubrication.**

CAUTION

- **Do not over tighten standard packing assembly before returning unit to operation. Jog the pump to check for proper rotation. Then allow pump to run for a short time, gradually tighten nuts (18) until dripping has been reduced to its normal level.**

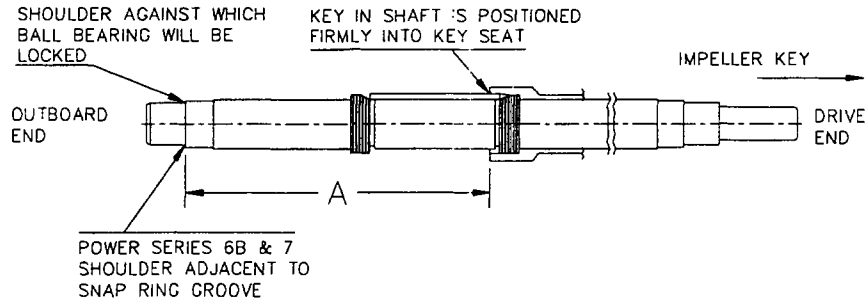

Figure 1 Shaft Sleeve Rotation-CW Rotation

Power Series	Pump Size	A	Power Series	Pump Size	A
1	2x2-1/2x9,10 & 12	8 -15/64	5	6x8x15,18 & 20	13-31/64
2	2-1/2 x 3x10 & 12	10-31/64	6B	8x10x12, 15 & 17	15-31/32
	3x4x10 & 14			8x10x21	
	4x5x10			10x12x12B & 15B	
3	4x5x11,13 & 15	11-11/64	7	12x14x15B & 18	18-3/64
4	4x6x18	11-59/64		14X16X18	
	5x6x11,15 & 17				
	6x8x11				
	8x8x11				

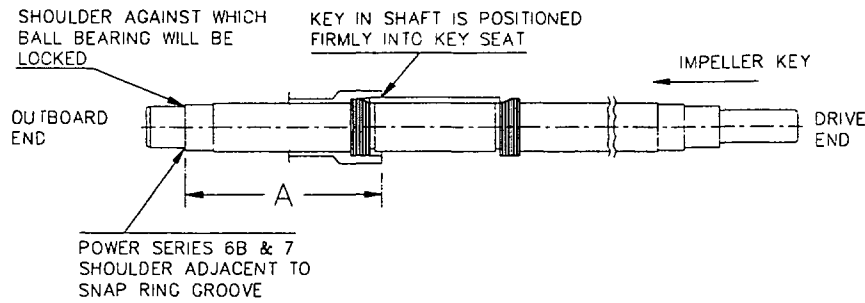

Figure 2 Shaft Sleeve Location-CCW Rotation

Power Series	Pump Size	A	Power Series	Pump Size	A
1	2x2-1/2x9,10 & 12	5-43/64	5	6x8x15,18 & 20	8-59/64
2	2-1/2 x 3x10 & 12	6-59/64	6B	8x10x12, 15 & 17	10-13/32
	3x4x10 & 14			8x10x21	
	4x5x10			10x12x12B & 15B	
3	4x5x11,13 & 15	7-7/64	7	12x14x15B & 18	12-31/64
4	4x6x18	7-55/64		14X16X18	
	5x6x11,15 & 17				
	6x8x11				
	8x8x11				

REPAIRS

ORDERING PARTS

When ordering parts, give pump serial number, size, and model number and a complete description and item number of each part. Refer to the drawing and parts list in the back of this manual.

You may order parts from your local Fairbanks Nijhuis™ distributor. Consult your local telephone yellow pages, under **Pumps**, for the office nearest you.

You may also order parts directly from the factory at the following address:

Fairbanks Nijhuis
3601 Fairbanks Ave.
Kansas City, KS 66106-0999
(913) 371-5000

RECOMMENDED SPARE PARTS

Refer to table 1 for a list of recommended spare parts. This list is for normal duty.

Where severe conditions exist or minimum down time is critical additional quantities and those items indicated should be considered.

RETURNING PARTS

All materials or parts returned to the factory must have prior approval and a "**Returned Goods Tag**", listing the material to be returned and the reasons for the return. All material to be returned should be carefully packed to avoid damage in route from rough handling or exposure to weather. Contact the factory for shipping instructions. All material is to be returned freight prepaid.

Fairbanks Nijhuis makes improvements on its products from time to time and reserves the right to furnish improved parts for repairs. A part that is received and is not identical in appearance, or has a different symbol from the original part, may be interchangeable. Examine the part carefully before contacting your Fairbanks Nijhuis representative. The parts should never be returned to the factory with-

out first obtaining proper authorization from your Fairbanks Nijhuis representative.

SERVICE

WARRANTY SERVICE:

For Warranty Service contact the factory at:
Fairbanks Nijhuis™
3601 Fairbanks Ave.
Kansas City, KS 66106-0999
(913) 371-5000

SERVICE AFTER WARRANTY

For service after warranty on this pump or any other pumping equipment contact:

Pump Services Group
1-800-648-PUMP

Or Write:

Pump Services Group
Fairbanks Nijhuis™
3601 Fairbanks Ave.
Kansas City, KS 66106-0999
(913) 371-5000

PREDICTED LIFE

The predicted life of parts subject to wear, shown in table 2, is based on pumping liquid without abrasives, the pump operating at sold conditions and that proper maintenance is performed.

The actual life encountered for the specific parts may vary significantly as a result of the content of liquid pumped, maintenance performed, actual operating conditions and other factors.

These predicted life figures are best engineering judgements and are not to be construed as an extension of warranty.

Table 1 Recommended Spare Parts

Ref No	Description	Quantity
*1	Impeller	1
*4	Pump Shaft	1
10	Water Seal Ring, set	1
14	Shaft Sleeve, set	1
16	Wear Ring, Casing, set	1
17	Wear Ring, Impeller, set	1
126	Deflector, set	1
163	Bearing, Radial	1
168	Bearing, Thrust	1
212	Packing set	1
456	Mechanical Seal, set	1

Table 2 Predicted Life

Ref. No.	Description	Predicted Life
1	Impeller	10 yrs
2	Casing, Lower	20 yrs
3	Casing, Upper	20 yrs
14	Shaft Sleeve	5 yrs
16	Wear Ring, Casing	5 yrs
17	Wear Ring, Impeller	5 yrs
163	Bearing, Radial	100,000 hrs
168	Bearing, Thrust	100,000 hrs
212	Packing	1 yr
456	Mechanical Seal	5 yrs

* Items are recommended for severe duty service only.

Table 3-Parts List

Ref No	Description
1	Impeller
2	Casing, Lower Half
3	Casing, Upper Half
4	Pump Shaft
6	Cap, Bearing Housing
10	Lantern Ring
14	Shaft Sleeve
16	Wear Ring, Casing
17	Wear Ring, Impeller
19	Gland
20	Stuffing Box Bushing
A20	O-ring, Sleeve
B20	Gasket, Bearing Housing Cover
102	Key, Impeller
118	End Cap, Bearing Housing
126	Deflector
157	Gasket, Casing
158B	Pin, Dowel
A158	Housing, Thrust Bearing
B158	Housing, Radial Bearing
159A	Lip Seal
A159	Cover, Thrust Bearing Housing Outer
D159	Cover, Radial Bearing Housing Outer
D159A	Lip Seal
161	Retaining Ring, Bearing
163	Bearing, Radial
168	Bearing, Thrust
212	Packing
272	Key, Coupling
31	Gland, Solid
31A	O-ring, Gland
456	Mechanical Seal

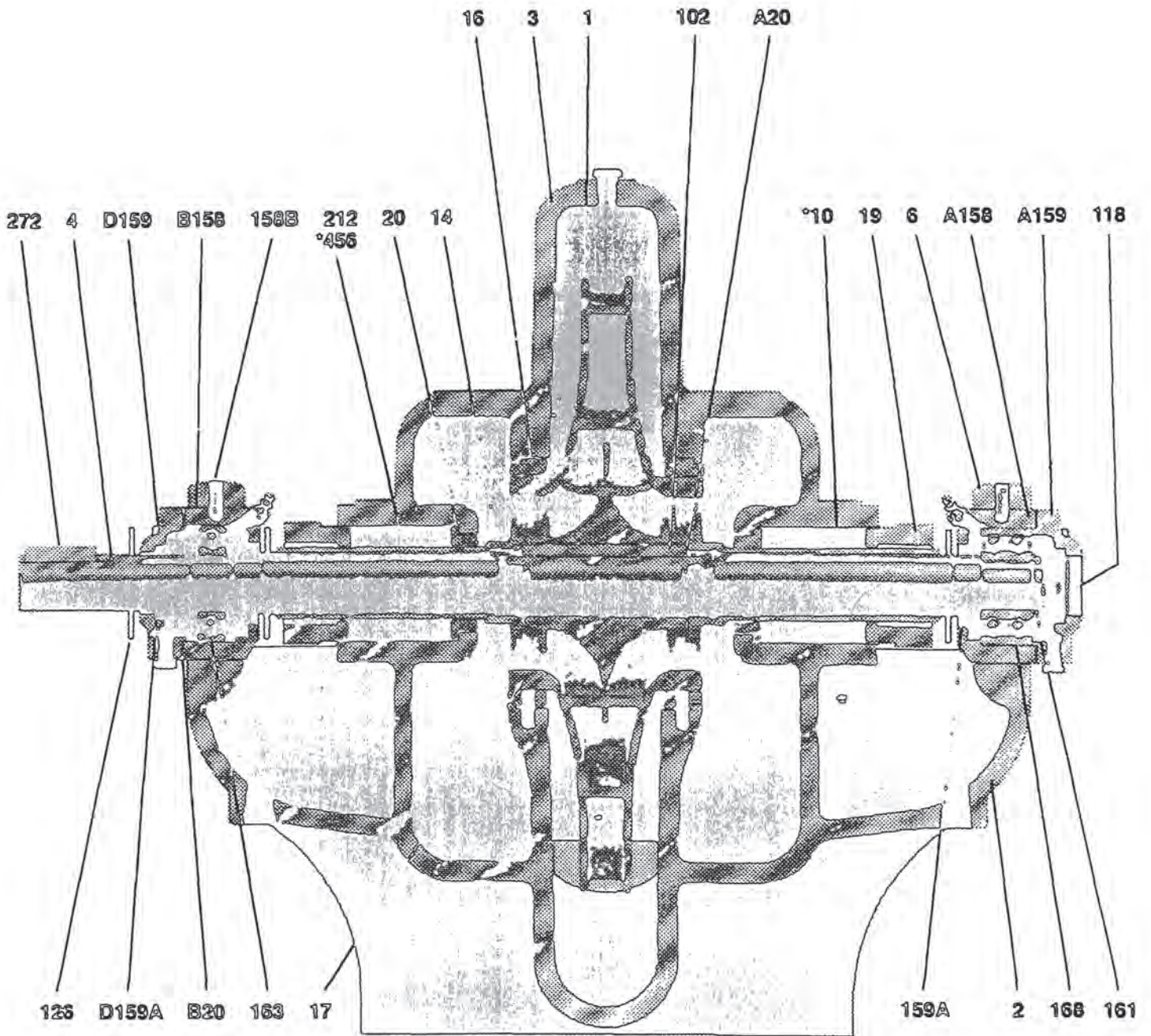

° PART NOT SHOWN

ASSEMBLY
MODEL 1820

 PENTAIR FAIRBANKS NIJHUIS™

