

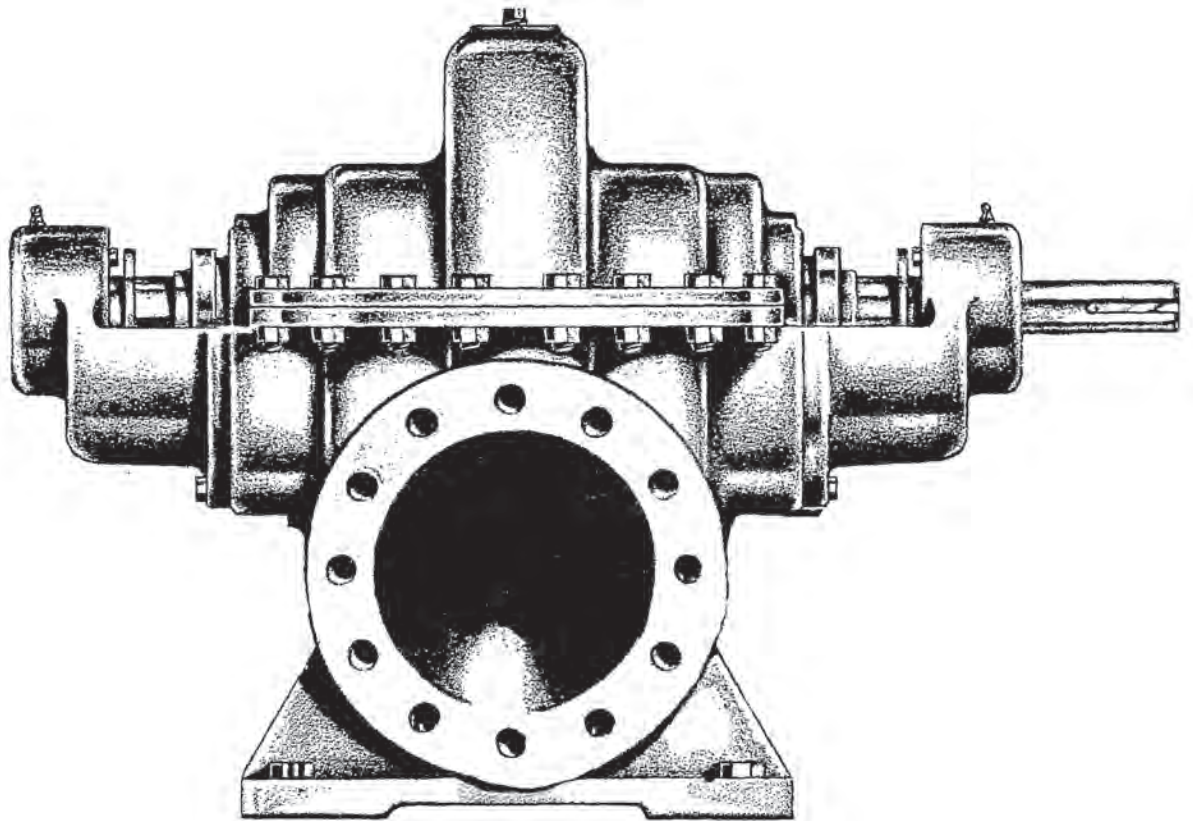

FAIRBANKS NIJHUIS™



MODEL 5800/5800F HORIZONTAL SPLIT-CASE AND FIRE PUMPS WITH REMOVABLE BEARING ARMS

INSTALLATION, OPERATION AND MAINTENANCE MANUAL

NOTE! To the installer: Please make sure you provide this manual to the owner of the equipment or to the responsible party who maintains the system.

TABLE OF CONTENTS**INSTALLATION, OPERATION AND
MAINTENANCE INSTRUCTIONS
5800/5800F WITH REMOVABLE BEARING ARMS**

STORAGE OF PUMPS	3
WARRANTY (KC-585)	4
INTRODUCTION	6
General Application	6
PUMP AND DRIVEN INSTALLATION	6
General	6
Location	6
Foundation	6
Alignment	6
Coupling Alignment	7
Grouting	7
Piping	7
INITIAL START UP AND OPERATING INSTRUCTIONS	7
MAINTENANCE	8
Bearing Lubrication	8
Stuffing Box	8
Packing Replacement	8
Pump Disassembly	8
Pump Assembly	9
ORDERING PARTS	10
RETURNING PARTS	10
DRAWINGS:	
Coupling Alignment	10
Indicator Location	11
Sectional 5800	12
Sectional - 5800 With Casing and Impeller Wearing Rings, and Mechanical Seals	13
Material Specifications	14
TROUBLE SHOOTING	15,16

NOTICE

CAUTION

IMPORTANT SAFETY NOTICE

THE INSTALLATION, USE AND OPERATION OF THIS TYPE OF EQUIPMENT IS AFFECTED BY VARIOUS FEDERAL, STATE AND LOCAL LAWS AND THE REGULATIONS CONCERNING OSHA. COMPLIANCE WITH SUCH LAWS RELATING TO THE PROPER INSTALLATION AND SAFE OPERATION OF THIS TYPE OF EQUIPMENT IS THE RESPONSIBILITY OF THE EQUIPMENT OWNER AND ALL NECESSARY STEPS SHOULD BE TAKEN BY THE OWNER TO ASSURE COMPLIANCE WITH SUCH LAWS BEFORE OPERATING THE EQUIPMENT.

CALIFORNIA PROPOSITION 65 WARNING:

WARNING:

This product and related accessories contain chemicals known to the State of California to cause cancer, birth defects or other reproductive harm.

STORAGE OF PUMPS

IF THE EQUIPMENT IS NOT TO BE INSTALLED AND OPERATED SOON AFTER ARRIVAL, STORE IT IN A CLEAN, DRY, WELL-VENTILATED PLACE, FREE FROM VIBRATION, MOISTURE, AND RAPID OR WIDE VARIATIONS IN TEMPERATURE. ROTATE THE SHAFT SEVERAL REVOLUTIONS. (NOT TO EXCEED EVERY TWO WEEKS) TO:

1. COAT THE BEARINGS WITH LUBRICANT,
2. RETARD OXIDATION OR CORROSION AND,
3. PREVENT POSSIBLE FALSE BRINELLING.

FOR OIL LUBE BEARINGS FILL THE RESERVOIR FULL OF OIL FOR STORAGE. DRAIN OIL TO THE PROPER LEVEL FOR START-UP. ROTATE THE SHAFT PERIODICALLY, ALSO NOT TO EXCEED EVERY TWO WEEKS.

CONSIDER A UNIT IN STORAGE WHEN:

1. IT HAS BEEN DELIVERED TO THE JOB SITE AND IS AWAITING INSTALLATION.
2. IT HAS BEEN INSTALLED BUT OPERATION IS DELAYED PENDING COMPLETION OF PLANT CONSTRUCTION.
3. THERE ARE LONG (30 DAY OR MORE) PERIODS BETWEEN OPERATION CYCLES.
4. THE PLANT (OR DEPARTMENT) IS SHUT DOWN.

NOTE: STORAGE REQUIREMENTS VARY DEPENDING ON THE LENGTH OF STORAGE, THE CLIMACTIC ENVIRONMENT AND THE EQUIPMENT. FOR STORAGE PERIODS OF THREE MONTHS OR LONGER, CONTACT THE MANUFACTURER FOR SPECIFIC INSTRUCTIONS. IMPROPER STORAGE COULD RESULT IN NON-WARRANTY COVERED RESTORATION REQUIREMENTS OR NON-WARRANTY COVERED PRODUCT FAILURES.

STANDARD TERMS AND CONDITIONS

LEGAL EFFECT: Except as expressly otherwise agreed to in writing by an authorized representative of Seller, the following terms and conditions shall apply to and form a part of this Quotation and any order resulting therefrom and any additional and/or different terms of Buyer's purchase order or other form of acceptance are rejected in advance and shall not become a part of any order resulting from this Quotation.

The rights of Buyer hereunder shall neither be assignable nor transferable except with the written consent of Seller.

Any order resulting from this Quotation cannot be cancelled or altered except with the written consent of Seller and upon terms which will indemnify Seller against all loss occasioned thereby. All additional costs incurred by Seller due to changes in design or specifications, modification of any order resulting from this Quotation or revision of product must be paid for by Buyer.

In addition to the rights and remedies conferred upon Seller by any contract resulting from this Quotation, Seller shall have all rights and remedies conferred at law and in equity and shall not be required to proceed with the performance of any order resulting from this Quotation if Buyer is in default in the performance of such order or of any other contract or order with Seller.

PRICES:

A. Prices for items of equipment included in the Quotation, other than equipment noted in Paragraph B, manufactured by Seller, are subject to escalation in accordance with Clause 1 below, unless Clause 2 is specifically stated in the price quotation portion of this Quotation.

CLAUSE 1 - The price for each item of equipment shall be escalated by the percentage increase of the published price for such item after applicable discounts in effect at the time of shipment, over the published price for such items after applicable discounts in effect at the date of this Quotation.

CLAUSE 2 - The quoted price for each item of equipment shall be subject to escalation in accordance with the price adjustment policy specified in Form KC 586.

B. Items of equipment purchased by Seller which are not covered by published prices and which are separately identified in this Quotation (such as motors, engines, controls, etc.) will be subject to escalation by the ratio of Seller's purchase price at the time of shipment over Seller's purchase price at the time of this Quotation.

TERMS OF PAYMENT: Unless otherwise specified in this Quotation, the terms of payment shall be as follows:

- a. On all orders under \$100,000, net cash within thirty (30) days after shipment.
- b. On all orders over \$100,000 as follows:
 - 15% on submittal of drawings
 - 25% on release to manufacture
 - 50% at time of shipment
 - 10% 30 days after shipment

These terms shall apply to partial as well as complete shipments. If any proceeding be initiated by or against Buyer under any bankruptcy or insolvency law, or in the judgment of Seller the financial condition of Buyer, at the time the equipment is ready for shipment, does not justify the terms of payment specified, Seller reserves the right to require full payment in cash prior to making shipment. If such payment is not received within fifteen (15) days after notification of readiness for shipment, Seller may cancel the order as to any unshipped item and require payment of its reasonable cancellation charges.

If Buyer delays shipment, payments based on date of shipment shall become due as of the date when ready for shipment. If Buyer delays completion of manufacture, Seller may elect to require payment according to percentage of completion. Equipment held for Buyer shall be at Buyer's risk and storage charges may be applied at the discretion of Seller.

Accounts past due shall bear interest at the highest rate lawful to contract for but if there is no limit set by law, such interest shall be eighteen percent (18%). Buyer shall pay all costs and expenses, including reasonable attorney's fees, incurred in collecting the same, and no claim, except claims within Seller's warranty of material or workmanship, as stated below, will be recognized unless delivered in writing to Seller within (30) days after date of shipment.

TAXES: All prices exclude present and future sales, use, occupation, license, excise, and other taxes in respect of manufacture, sales, or delivery, all of which shall be paid by Buyer unless included in the purchase price at the proper rate or a proper exemption certificate is furnished.

ACCEPTANCE: This Quotation is not an offer. All offers to purchase, quotations and contracts of sale are subject to final acceptance by an authorized representative at Seller's Kansas City plant.

DELIVERY: Except as otherwise specified in this Quotation, delivery will be F.O.B. cars point of shipment. In the absence of exact shipping instructions, Seller will use its discretion regarding best means of shipment. No liability will be accepted by Seller for so doing. All transportation charges are at Buyer's expense. Time of delivery is an estimate only and is based upon the receipt of all information and necessary approvals. The shipping schedule shall not be construed to limit Seller in making commitments for materials or in fabricating articles under this order in accordance with Seller's normal and reasonable production schedules.

Seller shall in no event be liable for delays caused by fires, acts of God, strikes, labor difficulties, acts of governmental or military authorities, delays in transportation or procuring materials, or causes of any

STANDARD TERMS AND CONDITIONS

kind beyond Seller's control. No provision for liquidated damages for any cause shall apply under this order. Buyer shall accept delivery within thirty (30) days after receipt of notification of readiness for shipment. Claims for shortages will be deemed to have been waived if not made in writing within ten (10) days after the receipt of the material in respect of which any such shortage is claimed. Seller is not responsible for loss or damage in transit after having received "In Good Order" receipt from the carrier. All claims for loss or damage in transit should be made to the carrier.

TITLE & LIEN RIGHTS: The equipment shall remain personal property, regardless of how affixed to any realty or structure. Until the price (including any notes given therefore) of the equipment has been fully paid in cash, Seller shall, in the event of Buyer's default, have the right to repossess such equipment.

PATENT INFRINGEMENT: If properly notified and given an opportunity to do so with friendly assistance, Seller will defend Buyer and the ultimate user of the equipment from any actual or alleged infringement of any published United States patent by the equipment or any part thereof furnished pursuant hereto (other than parts of special design, construction, or manufacture specified by and originating with Buyer), and will pay all damages and costs awarded by competent court in any suit thus defended or of which it may have had notice and opportunity to defend as aforesaid.

STANDARD WARRANTY: Seller warrants products of its own manufacture against defects in materials and workmanship under normal use, and service for one (1) year from date of installation or startup, but not more than eighteen (18) months after date of shipment. Accessories and components not manufactured by Seller are warranted only to the extent of the original manufacturer's warranty. Notice of the alleged defect must be given to Seller in writing with all identifying details including serial number, type of equipment and date of purchase within thirty (30) days of the discovery of same during the warranty period. Seller's sole obligation on this warranty shall be, at its option, to repair or replace or refund the purchase price of any product or part thereof which proves to be defective as alleged. No allowances will be made for repairs or alterations effected without specific written authorization from Seller.

If requested by Seller, such product or part thereof must be promptly returned to the manufacturer prior to any attempted repair; or sent to an authorized service station designated by the manufacturer. All shipping expenses are to be prepaid by the buyer. Seller accepts no responsibility for loss or damage, in transit, of goods, nor will any warranty claim be considered unless the returned goods are received intact and undamaged as a result of shipment. Repaired or replaced material returned to customer will be shipped F.O.B. the manufacturer's factory.

Seller warrants repaired or replaced parts of its own manufacture against defects in materials and workmanship under normal use and service for ninety (90) days or for the remainder of the warranty on the product being repaired. This warranty applies to the repaired or replaced part and is not extended to the product or any other component of the product being repaired.

Under the terms of this warranty, Seller shall not be responsible nor liable for:

- a. consequential, collateral or special losses or damages
- b. equipment conditions caused by fair wear and tear, abnormal conditions of use, accident, neglect or misuse of said equipment
- c. labor charges, loss or damage resulting from the supplying of defective part(s) or improper repairs by unauthorized person(s)
- d. damage caused by abrasive materials, chemicals, scale deposits, corrosion, lightning, improper voltage or mishandling

Seller reserves the right to substitute new equipment and/or improve the part(s) on any equipment judged defective without further liability. All repairs and/or services performed by Seller, not adjusted as covered by this warranty, will be charged in accordance with the current equipment and service prices.

This warranty is VOID unless the purchaser provides protective storage, installs and maintains the equipment in accordance with published instructions.

Credit will NOT be allowed nor shipment accepted on any part(s) or equipment returned unless prior approval in writing has been obtained.

THIS WARRANTY IS THE SOLE WARRANTY OF SELLER AND ANY OTHER WARRANTIES EXPRESS, IMPLIED IN LAW OR IMPLIED IN FACT, INCLUDING ANY WARRANTIES OF MERCHANTABILITY AND FITNESS FOR USE, ARE HEREBY SPECIFICALLY EXCLUDED.

No employee of the Seller and no agent, dealer or distributor has any authority to change or enlarge the terms of this warranty to obligate the Seller to other than strictly the terms of this written warranty.

LIABILITY LIMITATIONS: Under no circumstances shall the Seller have any liability for liquidated damages or for collateral, consequential or special damages or for loss of profits, or for actual losses or for loss of production or progress of construction, whether resulting from delays in delivery or performance, breach of warranty, negligent manufacture or otherwise. The aggregate total liability of Seller in connection with the performance of this order, whether for breach of contract or warranty, negligence, or otherwise, shall in no event exceed the contract price. Buyer agrees to indemnify and hold harmless Seller from all claims by third parties in excess of these limitations.

Since the compliance with the various Federal, State and Local laws and regulations concerning occupational health and safety and pollution are affected by the use, installation and operation of the equipment and other matters over which the Seller has no control, the Seller assumes no responsibility for compliance with those laws and regulations, whether by way of indemnity, warranty or otherwise.

INTRODUCTION

This manual contains descriptions and instructions which are the result of carefully conducted engineering and research efforts. It is designed for the safe and efficient installation, operation and maintenance of your pump. **Failure or neglect to properly install, operate or maintain your pump may result in personal injury, property damage or unnecessary damage to the pump. Read this manual and all other equipment manuals carefully.**

The purpose of this manual is to supply adequate instructions for installation, operation and maintenance of your pump. However, this manual shall not in any way take precedence over or abrogate the requirements of NFPA 20 for the installation and use of centrifugal fire pumps.

General Application

The 5800 pumps are horizontal split case design, with the casing being split on the horizontal centerline. The only moving part is the rotating assembly which is installed using high quality steel ball bearings.

This pump is a new compact design with a shorter bearing to bearing span. This results in less deflection under hydraulic load and less wear on sleeves, bearings and packing.

The stuffing box packing is lubricated by the fluid being pumped. When the pump is in operation, the fluid is channeled through a cast water passage in the upper casing directly to the stuffing box, or by a connection to the stuffing box from an outside source.

The pump may be supplied with a mechanical seal configuration. Also, it may be supplied with impeller wear rings, and with an oil lubrication system for the bearings.

PUMP AND DRIVER INSTALLATION

General

Carefully read all sections of this manual, which apply to pump and driver installation, prior to beginning work.

Upon receipt of shipment, unpack and inspect pump and driver assemblies and individual parts to assure none are missing or damaged. Report any damage or shortages immediately to the factory, and to the transportation company involved.

The pump and driver assemblies are mounted on a structural steel base and are aligned at the factory. However, the alignment may be disturbed in transit or by incorrect leveling of the base on the foundation. Alignment should be checked after the unit is leveled on the foundation, after grouting has set and foundation bolts are tightened, and after all piping is accomplished.

When the driver is to be mounted at the installation site, the pump is positioned on the structural steel base at the factory. However, the driver bolt holes are not drilled or tapped. When the pump and driver are mounted on separate base structures, the pump should be leveled and aligned first; then the driver can be leveled and lined up with the pump.

To facilitate alignment at the installation site, neither the pump or driver is doweled to the base structure at the factory.

Location

The pump and driver should be located in an area that will permit periodic inspection and maintenance. Head room should be provided when it is necessary to use cranes. All units should be installed in a dry and dust free location.

WARNING: DO NOT PICK UP THE COMPLETE UNIT BY THE DRIVER OR PUMP.

When it is necessary to move or lift the complete unit, a chain or suitable lifting device should be attached to each corner of the base structure. The individual driver or pump may be fitted by the provided eye bolts.

The pump should be installed as near the fluid supply as possible so a short, direct suction pipe can be used to hold suction loss to a minimum. The discharge piping should be direct and with as few elbows and fittings as possible.

NPSH available must be equal to or greater than NPSH required for the particular application.

Foundation

The foundation should be a level surface sufficient to prevent vibration and to form a permanent rigid support for the base structure. The most satisfactory foundations are concrete. Foundation bolts of the proper size should be imbedded in the foundation in pipe sleeves with an I.D. 2-1/2 times larger than the bolt diameter to allow for final positioning of the unit.

Alignment

Lower the unit onto the foundation positioning the base structure so the anchor bolts are correctly aligned with the holes in the base. Disconnect the coupling halves and **do not reconnect until all alignment operations are complete.** (See Fig. 1).

The base structure should be supported on metal shims or metal wedges. The support pieces should be placed directly under the part of the base carrying the greatest weight, and spaced close enough to give uniform support. (See Fig. 1).

Adjust the metal supports or wedges until the shafts of the pump and driver are level. Check the coupling faces as well as the suction and discharge flanges of the pump for horizontal or vertical position by means of a level. Corrections can be accomplished, if necessary, by adjusting the supports under the base.

When the pump and driver are in position there should be 1/8" minimum clearance between the shaft ends or as specified on the setting plan.

Coupling Alignment

When installing and aligning a coupling, it must be checked **carefully**. A flexible coupling **should not** be used to compensate for misalignment of the pump and driver. The purpose of a flexible coupling is to compensate for mis-alignment due to temperature changes and to permit independent end movement of the pump and drive shaft.

Angular alignment is accomplished by inserting a taper or feeler gage at four points between the coupling faces and comparing the distance between the faces at four points spaced at 90° intervals around the couplings. Rotate each coupling individually and check at all four points. The unit will be in angular alignment when the measurements show that the coupling faces are the same distance apart at each point. (See Fig. 2).

Parallel alignment is accomplished by placing a straight edge across both coupling rims at the top, bottom, and both sides. The unit will be in parallel alignment when the straight edge rests evenly on the coupling rim at all four positions. Care must be taken to hold the straight edge parallel to the axis of the shaft. (See Fig. 3).

For couplings other than Fairbanks Nijhuis™ manufacture, refer to the instructions supplied for the respective couplings.

Coupling misalignment is corrected by placing shims under the driver or pump mounting feet. After each change, recheck the alignment of the coupling halves. Adjustment in one direction may disturb adjustments already made in another direction.

Grouting

When the alignment is correct, the foundation bolts should be **tightened evenly but not too firmly**. The unit should now be grouted using high A-Grade non-shrinking grout. The inside of the base structure should be filled to the top of side rail with grout.

Allow the grout to fully cure before piping, or operation of the pump. Be sure to fully tighten foundation bolts before piping or pump operation is started.

Piping

All piping should be independently supported near the pump

so that pipe strain will not be transmitted to the pump casing. The suction pipe must be air tight and inclined upward to the pump flange to avoid air pockets which will impair satisfactory pump operation. The pump must **never** be throttled by the use of a valve in the suction line. The discharge pipe should be as direct as possible, with a minimum number of valves and fittings to reduce pipe friction losses. The suction and discharge piping should be one or two sizes larger than the pump flange sizes, especially where the piping is of considerable length. Eccentric reducers should be used on the suction line to increase the suction line size. The use of this type of reducer will help avoid air pockets in the suction line. A check valve and gate valve should be used in the discharge line. The check valve, placed between the pump and the gate valve, is to protect the pump from reverse rotation. The gate valves are used in *priming and starting and when the pump is to be shut down*. For nominal suction lifts, a foot valve in the suction line will facilitate priming.

In a new installation, care should be taken to prevent dirt, pipe scale, welding beads, or any type of foreign matter from entering the pump. The suction system should be thoroughly flushed; if the liquid being pumped contains foreign matter, a strainer should be installed in the suction. The strainer must have a net area of at least three times the area of the suction pipe.

IMPORTANT: WHEN CONNECTING PIPING TO THE PUMP, THE CONNECTION SHOULD BE MADE WITH THE PIPE IN A FREE BUT SUPPORTED STATE, AND WITHOUT THE NEED TO APPLY VERTICAL OR SIDE PRESSURE TO OBTAIN ALIGNMENT OF THE PIPING WITH THE PUMP FLANGE.

CAUTION: AFTER ALL PIPING IS CONNECTED, THE PUMP AND DRIVER ALIGNMENT SHOULD BE RECHECKED.

Rotation

Before connecting the two coupling halves, start the driver and verify rotation is in the proper direction. The correct pump rotation is indicated by a directional arrow on the pump casing.

INITIAL START-UP AND OPERATING INSTRUCTIONS

Variations may exist in both the equipment used with these pumps and in the particular installation of the pump and driver. Therefore, specific operating instructions are not within the scope of this manual. However, there are some general rules and practices that apply to all pump installations and operation.

CAUTION: BEFORE STARTING AND OPERATING THE PUMP, READ THE FOLLOWING INSTRUCTIONS.

1. Before starting pump, install coupling guards around exposed rotating parts, as required.
2. Before starting pump, rotate the unit by hand to assure all moving parts are free.
3. Observe all caution or danger tags attached to the equipment.

1. Never run the pump dry as the close running fits within the pump are water lubricated. Running dry may result in pump seizure.
5. Before starting pump, the casing and suction line must be filled with water. The pump may be primed by using an ejector, exhausted, vacuum pump or by filling and venting with a foot valve on the suction line.
6. Refer to the instruction manuals provided by the manufacturers of other equipment used with the pump for installation, operation and maintenance instructions.
7. If excessive vibration or noise occurs during operation, shut the pump down and consult with a Fairbanks Nijhuis™ representative. Only Fairbanks Nijhuis qualified representatives should be engaged to service this equipment.
8. Keep the stuffing box adjusted so there is sufficient leakage to lubricate the packing and assure a cool stuffing box. (See maintenance instructions).

If the pumps are stored for long periods of time prior to installation and operation, refer to Fairbanks Nijhuis Storage of Pumps Notice, Form KC1309, located at the front of this manual.

MAINTENANCE

Bearing Lubrication

Fairbanks Nijhuis pumps are equipped with high grade antifriction bearings which are lubricated at the factory for approximately six months average service. Periodic inspections should be made by loosening the bearing covers enough to permit visual examination of the bearings.

Do not inspect bearings while pump is operating. The cover and bearing cavity should be approximately half full of lubricant.

The pump is equipped with pressure gun fittings for each bearing. The bearings should be lubricated with a Lithium Base NLGI 2 grease from a reputable manufacturer.

WARNING: DO NOT ATTEMPT TO LOOSEN BEARING COVERS OR LUBRICATE BEARINGS WHILE PUMP IS RUNNING.

In the event pumps are in service and operating in an area having high ambient temperatures, special greases may be required. Contact a lubrication engineer or a Fairbanks Nijhuis representative.

Immediately after lubrication, bearing temperature may rise above normal operating temperature. This should stabilize within 4 to 8 hours. The frequency of lubrication depends on the operating conditions.

If the bearings are oil lubricated, use a good grade of SAE 20 automotive type oil either detergent or non-detergent which contains nonfoaming, nonoxidation and rust inhibitor agents.

If the pump is supplied with a constant level oiler, assemble the oiler to the bearing housing. The oiler is located in a way to predetermine the oil level in the housing. Fill the oiler and let it drain into the housing until the oil level remains constant in the sight glass. When this is accomplished the correct oil level is attained.

Stuffing Box

The stuffing boxes on Fairbanks Nijhuis pumps are packed at the factory with a good grade of packing. However, all packing is subject to wear and should be given regular inspections and, if necessary, adjustments.

Adjustment is accomplished by tightening the gland nuts wrench tight, and then loosening so they can be adjusted with finger pressure, to allow a small flow of liquid, to lubricate the packing. If the flow of liquid has increased and cannot be reduced by a slight tightening of the glands, it is time to replace the packing and/or shaft sleeve.

CAUTION: DO NOT TIGHTEN THE GLAND TO STOP ALL LEAKAGE. LEAKAGE IS NECESSARY TO INSURE THE COOLING AND LUBRICATION OF THE PACKING AND TO PREVENT SLEEVE DAMAGE.

Water lubrication is supplied to the stuffing box by a connection from an outside source or by a cast in water passage in the upper casing.

Packing Replacement

When replacing packing, use a good grade of soft square long fiber asbestos packing thoroughly graphited. The replacement procedure should be as follows:

- A. Unbolt and remove the split gland.
- B. Use a packing hook to remove the worn packing and water seal rings. Note location of water seal ring, relative to amount of packing on each side of ring.
- C. Clean the packing box and shaft sleeve.
- D. Inspect the shaft sleeve for wear or rough finish. Replace if necessary.
- E. Install the new packing and water seal ring. Stagger the packing end joints 180° and firmly seat each packing ring.
- F. Reinstall the split gland and tighten the gland nuts wrench tight.
- G. Loosen the gland nuts so they can be adjusted with finger pressure to obtain correct leakage for lubrication, after start-up.

Pump Disassembly

Major pump maintenance, beyond lubrication and adjustment or replacement of packing, will require disassembly of the pump. When disassembly is necessary the following step by step procedure will apply:

- A. Lock out the power to the driver, close suction and discharge valves, and drain the pump. Disconnect the couplings between the pump and driver. Remove the oilers

- (if the pump is equipped with an oil lubrication system).
- B. Remove the casing cap-screws, the gland nuts, and the upper casing.
 - C. Remove the cap screws and pins that attach the bearing housings to the lower casing. The pins can be removed by use of the threaded holes in the pins.
 - D. Using a double rope sling, remove the rotor assembly from the lower casing.
 - E. Remove the cap screws in the bearing covers and remove the bearing housings.
 - F. Remove the outer snap ring at the thrust bearing end of the shaft. With the assistance of a bearing puller, remove both bearings.
 - G. Remove the inner snap ring at the thrust bearing end. Remove bearing covers, slingers, casing wear rings, water seal rings, and stuffing box packing. If the pump is equipped with mechanical seals, refer to the mechanical seals instructions supplied with the pump.

If the pump has an oil lubrication system, remove the seals from the bearing covers and housings; remove the "O" rings and pick up rings.

- H. Remove the shaft sleeve nuts.
IMPORTANT: THE SHAFT SLEEVES AND NUTS ARE SECURED WITH A LOCTITE COMPOUND. TO REMOVE, HEAT UNIFORMLY TO 350°F–400°F TO SOFTEN THE LOCTITE.

WARNING: USE HEAT RESISTANT GLOVES WHEN HANDLING HOT PARTS.

- J. Slide the impeller off the shaft and remove the impeller key.

After the pump is disassembled, each part should be thoroughly cleaned and inspected for wear or damage. Any parts showing signs of wear or damage should be replaced.

The pump may be equipped with impeller wearing rings. If the rings require replacement, remove the dowel screws and chisel/cut the rings into at the dowel hole location. If the rings are threaded on, remove the dowel screws and unscrew the rings from the impeller. If the pump is clockwise in rotation, the wearing ring on the drive end will have left hand threads; the ring on the thrust side will have right hand threads.

Pump Assembly

Instructions for assembly of the pump will be essentially the reverse order of the instructions for disassembly. However, some special techniques are required.

CAUTION: READ THE ASSEMBLY INSTRUCTION CAREFULLY PRIOR TO BEGINNING WORK.

- A. If the pump is equipped with impeller wearing rings, install the new rings with a press or by using a hammer and a block of wood. Re-dowel 15°-20° from old dowel location. If the rings are a threaded configuration, screw each ring on the impeller full depth of threads and redowel.

- B. Thoroughly clean the pump shaft to remove oil, grease, and other types of foreign materials. Insert impeller key into the keyway slot of the pump shaft. Slide the impeller onto the shaft and over the key.

- C. Apply a bead of Loctite®, Catalog 271 or 601, around the shaft approximately 2 inches from the impeller hub and at the threaded end, where the shaft sleeve nut is installed. With a rotating motion, slide the shaft sleeves over the shaft until they butt firmly against the impeller hub. Apply 2 or 3 drops of Loctite®, 271 or 601, to the shaft threads and install the shaft sleeve nuts. To accomplish linear positioning of the impeller, leave an equal amount of threads exposed on each end of the shaft after the nuts are installed and properly tightened.

CAUTION: LINEAR POSITION OF THE IMPELLER MUST BE OBTAINED AND THE SHAFT SLEEVE NUTS TIGHTENED WITHIN 10 MINUTES AFTER LOCTITE IS APPLIED. ALLOW 4 HOURS AFTER LOCTITE IS APPLIED BEFORE OPERATING PUMP.

NOTE: If the pump is equipped with a constant level oiler, install the seals in the bearing covers and housings. Assemble the "O" rings on the bearing covers and the pick up rings between the bearings and covers prior to installing bearings.

- D. Install the slingers on each end of the pump shaft. Install radial and thrust bearing covers on the shaft. Install the inner snap ring at the thrust bearing end of the shaft. Install both radial and thrust bearings.

NOTE: The pump is designed to have .000 to .001 interference fit between the bearings and the shaft.

- E. Install outer snap ring at the thrust bearing end of the shaft. Position the snap ring inside the thrust bearing housing (grease lubricated only). Pack both bearings approximately half full with a Lithium Base NLGI 2 all purpose bearing grease. Install the bearing housing with the snap ring over the thrust bearing. Using capscrews, securely bolt the covers to the bearing housings.

- F. Using a double rope sling, lower the rotor assembly into position in the lower casing.

- G. Using the capscrews and pins, attach the bearing housings to the lower casing.

CAUTION: BE SURE THE MATING SURFACES OF THE BEARING ARMS AND PUMP CASING ARE CLEAN AND FREE FROM BURRS, AS THIS WILL AFFECT THE SHAFT ALIGNMENT.

The capscrews in the housing should be lightly torqued and the alignment of the rotating assembly checked by attaching an indicator to the shaft and sweeping the packing box bore section of the lower casing. This is accomplished by rotating the shaft. The total indicator reading should not exceed .003. The alignment may be corrected by lightly tapping the appropriate bearing housing. Once alignment is obtained, firmly tighten the capscrews and recheck alignment.

NOTE: If alignment cannot be obtained within .003 total indicator reading, at each end, contact a Fairbanks Nijhuis™ pump representative. **DO NOT OPERATE THE PUMP.** (See Fig. 4).

- H. Inspect upper casing to assure water passage is clean and free of foreign materials. Apply a small amount of grease to the gasket between the upper and lower casings;

position pins in casing wear rings to align with slots in lower casing; lower upper casing into position and install capscrews. A new gasket should be used.

- J. Install packing, water seal rings and split glands. (See packing replacement section of this manual).
- K. Restart pump per Initial Start-Up and Operating Instructions of this manual.

Ordering Parts

When ordering spare or replacement parts, give pump serial number, size and figure number, and a complete description and item number of each part. Refer to the drawing and parts list in the back of this manual. Your order may be forwarded to your nearest Fairbanks Nijhuis™ distributor or directly to the factory.

NOTE: The upper and lower casing are always furnished as an assembly.

Returning Parts

All materials or parts returned to the factory must have prior approval and a Fairbanks Nijhuis "Returned Goods Tag" to accompany them. Unnecessary delays and wasted efforts

will be avoided by using the proper procedure in returning parts or equipment.

Contact your nearest Fairbanks Nijhuis distributor, listing the material to be returned and the reasons for the return. He will contact the factory to obtain approval for the return and to obtain the necessary "Returned Goods Tag" if the return is approved. You will be notified of the reasons if the approval is not given.

All material to be returned should be carefully packed to avoid damage in route from rough handling or exposure to weather. The "Returned Goods Tag" will give shipping instructions. All material is to be returned freight prepaid unless otherwise instructed.

This company makes improvements on its products from time to time and reserves the right to furnish improved parts for repairs when such parts are interchangeable. A part that is received and is not identical in appearance or has a different symbol from the original part, may be interchangeable. Examine the part carefully before contacting your Fairbanks Nijhuis representative. The parts should never be returned to the factory without first obtaining proper authorization from your Fairbanks Nijhuis representative.

COUPLING ALIGNMENT

FIGURE 1

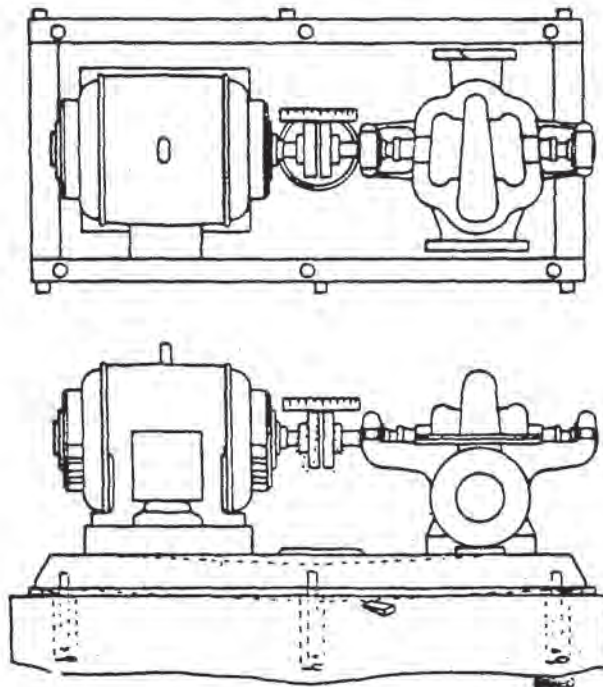
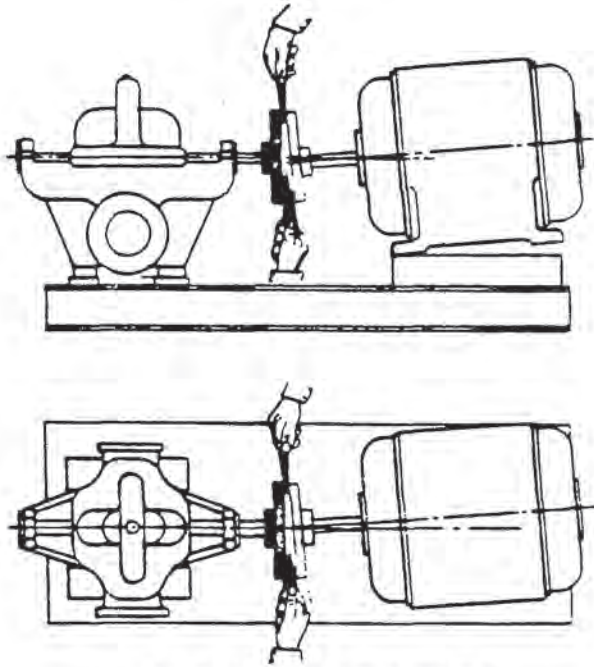
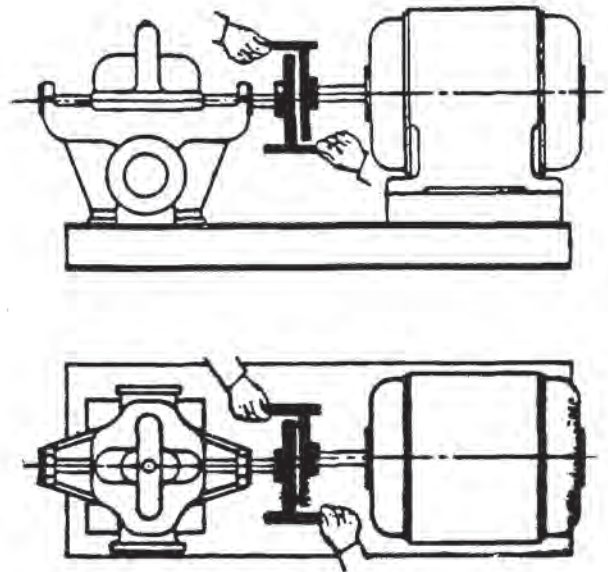

FIGURE 2



ANGULAR ALIGNMENT

FIGURE 3



PARALLEL ALIGNMENT

FIGURE 4

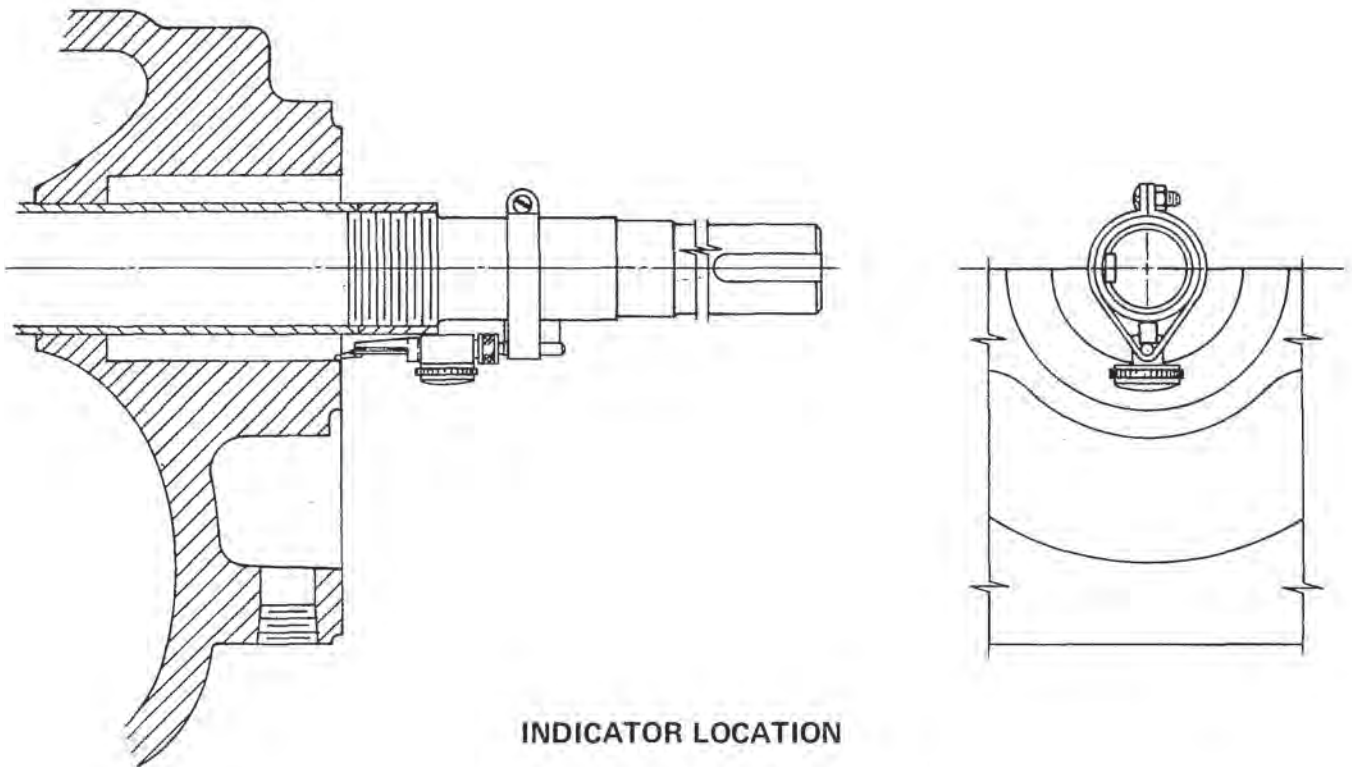

INDICATOR LOCATION

**5870 - HIGH SPEED FIRE PUMP WITH REMOVABLE
BEARING ARMS, CASING WEARING RINGS AND PACKING**

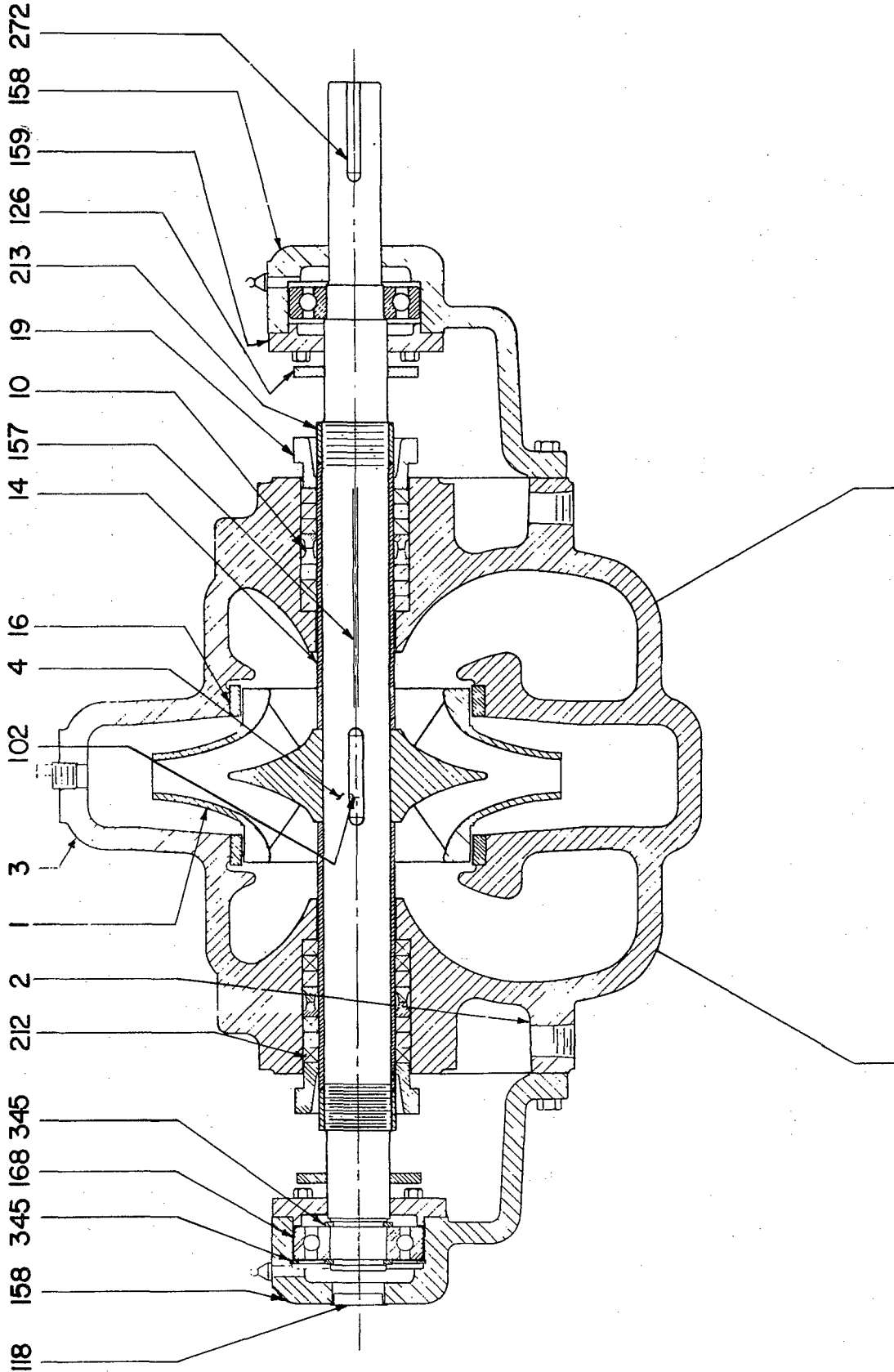

4" FIGURE 5826 WITH CASING AND IMPELLER RINGS MECHANICAL SEAL AND OIL LUBE BEARING HOUSING

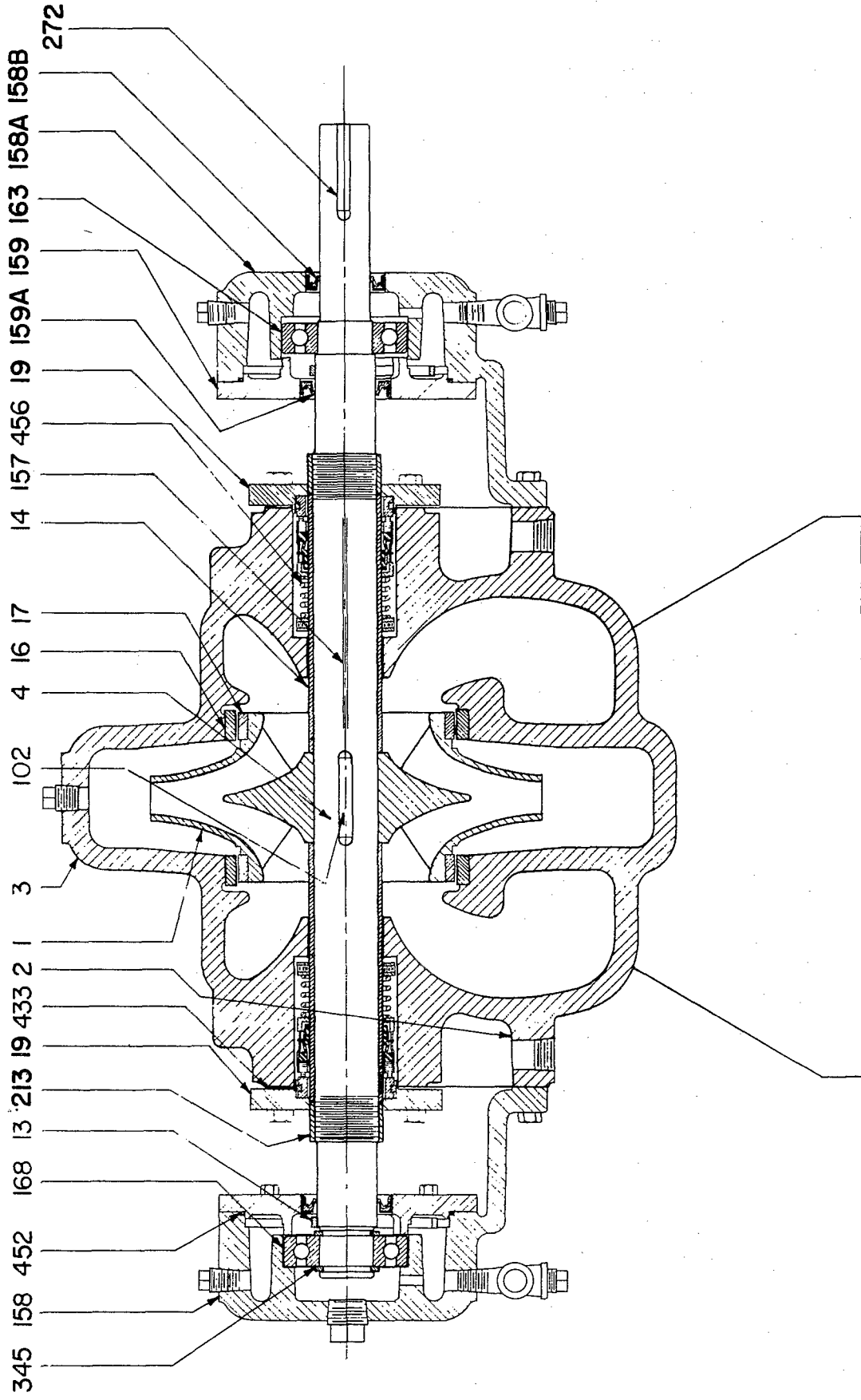

REF. NO.	DESCRIPTION
1	Impeller
2	Lower Casing Half
3	Upper Casing Half
4	Shaft
6	Bearing Housing Cap
10	Water Seal Ring
14	Shaft Sleeve
16	Casing Wear Ring
17	Impeller Wearing Ring
19	Gland Half
20	Stuffing Box Washer
95	Stuffing Box Bushing
102	Impeller Key
118	Bearing Housing Closure
157	Casing Gasket
158	Thrust Bearing Housing
158A	Radial Bearing Housing
159	Bearing Housing Cover
161	Bearing Locknut
162	Bearing Lockwasher
163	Radial Bearing
168	Thrust Bearing

REF. NO.	DESCRIPTION
196	Bearing Housing Lip Seal
212	Stuffing Box Packing
213	Shaft Sleeve Nut
272	Coupling Key
345	Snap Ring
452	"O" Ring
456	Mechanical Seal
None	Bearing Housing Cover Lip Seal
None	Bearing Lubrication Fitting
None	Priming Tap Plug
None	Water Seal Tap Plug
Not Shown	Drain Tap Plug
Not Shown	Gauge Tap Plug
Not Shown	Casing Capscrew
Not Shown	Casing Taper Pin
Not Shown	Casing Wear Ring Dowel Pin
Not Shown	Bearing Housing Cover Capscrew
Not Shown	Bearing Housing Dowel Pin
Not Shown	Bearing Housing Cap Capscrew
Not Shown	Gland Bolt
Not Shown	Gland Nut

**FAIRBANKS NIJHUIS™
TROUBLESHOOTING SERVICE GUIDE**

NO DISCHARGE

- | | |
|---|--|
| <ul style="list-style-type: none">1 Pump not primed2 Speed too low | <ul style="list-style-type: none">1 Check for proper venting of casting2 Check for and remove any obstruction in suction line1 Determine whether or not the motor is across the lines and receives full voltage. Correct if required2 See—Excessive power consumption |
|---|--|

INSUFFICIENT DISCHARGE

- | | |
|--|---|
| <ul style="list-style-type: none">1 Speed too low2 Impeller partially plugged3 Obstruction in piping | <ul style="list-style-type: none">1 Determine whether or not the motor is across the lines and receives full voltage. Correct if required2 See—Excessive power consumption1 Remove upper half casing and clean impeller as required1 Remove upper half casing and clean impeller as required |
|--|---|

INSUFFICIENT PRESSURE

- | | |
|--|--|
| <ul style="list-style-type: none">1 Speed too low2 Excessive wearing ring | <ul style="list-style-type: none">1 Determine whether or not the motor is across the lines and receives full voltage. Correct if required2 See—Excessive power consumption1 Correct as outlined in Maintenance section |
|--|--|

EXCESSIVE POWER CONSUMPTION

- | | |
|---|---|
| <ul style="list-style-type: none">1 Rotating element binds2 Packing too tight3 Bearings defective4 Coupling misaligned | <ul style="list-style-type: none">1 Remove upper half casing and correct as required1 Loosen gland nuts and retighten, finger-tight1 Replace as outlined in Assembly section1 Correct as outlined in Alignment section |
|---|---|

EXCESSIVE STUFFING BOX LEAKAGE

- | | |
|--|---|
| <ul style="list-style-type: none">1 Packing too loose2 Insufficient packing3 Shaft sleeves grooved | <ul style="list-style-type: none">1 Tighten gland nuts, finger-tight1 Add packing as outlined in Assembly section1 Replace sleeve as outlined in Assembly section |
|--|---|

VIBRATION OR NOISE

- | | |
|--|--|
| <ul style="list-style-type: none">1 Coupling misalignment2 Foundation bolts loose3 Rotating element binds4 Packing too tight5 Bearings defective | <ul style="list-style-type: none">1 Correct as outlined in Coupling Alignment section1 Correct as outlined in Foundation section1 Remove upper half casing and correct as required1 Loosen gland nuts and retighten, finger-tight1 Replace as outlined in Assembly section |
|--|--|

BEARINGS OVER-HEATING

- | | |
|---|---|
| <ul style="list-style-type: none">1 Coupling misalignment2 Excessive grease3 Rotating element binds | <ul style="list-style-type: none">1 Correct as outlined in Coupling Alignment section1 Remove bearing housing plugs and allow excess to drain1 Remove upper half casing and correct as required |
|---|---|

STUFFING BOX OVER-HEATING

- | | |
|--|---|
| <ul style="list-style-type: none">1 Packing too tight2 Water line to stuffing box plugged | <ul style="list-style-type: none">1 Loosen gland nuts and retighten, finger-tight1 Disconnect line and correct as required |
|--|---|

