

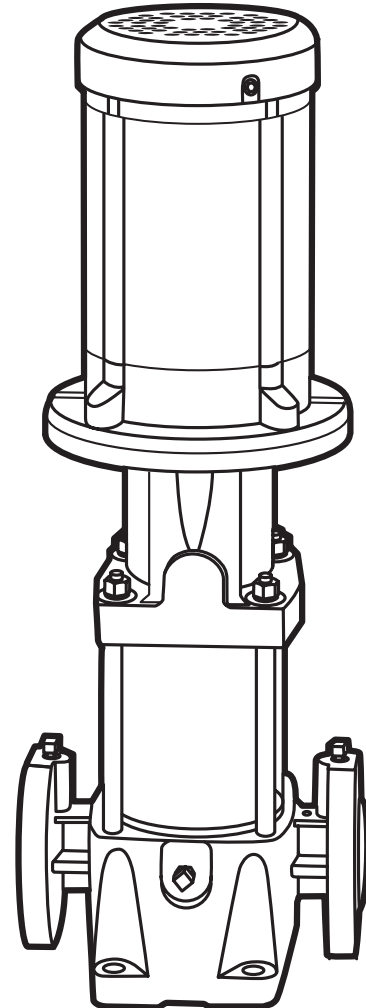

# FAIRBANKS NIJHUIS™

Record the following information from the motor and pump nameplates for future reference:

Pump Model No.	
Bill of Material No.	
Motor Model No.	
Motor Serial No.	
HP	Volts/Hz/Ph
Rated Amp Draw	



## PVM – CAST IRON PVMX – 316 STAINLESS STEEL **SINGLE AND THREE PHASE VERTICAL MULTISTAGE PUMPS** **INSTALLATION AND OPERATING INSTRUCTIONS**

NOTE! Read and understand the pump and motor instructions before attempting to install, disassemble or repair the pump.

## VERTICAL MULTISTAGE PUMPS

### TABLE OF CONTENTS:

Safety Instructions .....	2
Applications and Operating Ranges.....	2-4
Installation.....	5-6
Electrical .....	6
Operation.....	7-8
Maintenance .....	9-12
Troubleshooting Guide .....	13
Repair Parts .....	14-17

Carefully read and follow all safety instructions in this manual or on pump.

**▲ This is the safety alert.** When you see this symbol on your pump or in this manual, look for one of the following signal words and be alert to the potential for personal injury.

**▲ Danger:** Warns about hazards that **will** cause serious personal injury, death or major property damage if ignored.

**▲ Warning:** Warns about hazards that **can** cause serious personal injury, death or major property damage if ignored.

**▲ Caution:** Warns about hazards that **will** or **can** cause minor personal injury or property damage if ignored.

**▲ Warning: California proposition 65 warning**  
This product and related accessories contain chemicals known to the State of California to cause cancer, birth defects or other reproductive harm.

The word **NOTICE** indicates special instructions that are important but not related to hazards.

To avoid serious or fatal personal injury and possible property damage, carefully read and follow the safety instructions.

1. Install pump according to all code requirements.
2. Compare pump nameplate data with desired operating range.
3. Pump only liquids compatible with pump component materials (that is, liquids that will not attack the pump).
4. Make sure plumbing is adequate to handle system pressure.
5. Periodically perform maintenance inspection on pump and system components.
6. Wear safety glasses at all times when working on pumps.

### INSPECT THE SHIPMENT:

The vertical multistage centrifugal in-line pump has been carefully inspected and packaged to assure safe delivery. Inspect the pump and fittings and report to the carrier any items that are damaged or missing.

### CONFIRM THAT YOU HAVE THE RIGHT PUMP:

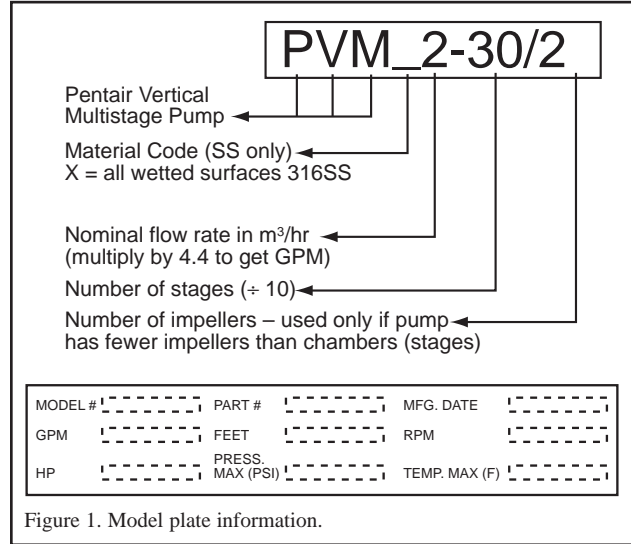

Figure 1. Model plate information.

### APPLICATIONS AND OPERATING RANGES:

Pentair multistage in-line centrifugal pumps are designed for liquid transfer, circulation, and pressure boosting of hot or cold clean water or other thin, nonexplosive liquids, not containing solid particles or fibers, which will not chemically attack the pump materials.

Typical applications include:

- Municipal water supply and pressure boosting
- Boiler feed and condensate systems
- Cooling water systems
- Irrigation
- Fire fighting

Maximum Ambient Temperature ..... 104°F (40°C)

Liquid Temperature Range .....5°F to 250°F  
(-15°C to +121°C)

Maximum Permissible Operating Pressure Curves .....See Figure 4

Maximum Inlet Pressure:..... See Table III  
Table III shows the maximum permissible inlet pressure. However, the actual inlet pressure plus the pressure when the pump is running against a closed valve must always be lower than the *Maximum Permissible Operating Pressure*.

Electrical Data..... See motor nameplate

Dimensions and Port-to-Port Lengths ..... See Figures 2A, 2B, 3A and 3B

## VERTICAL MULTISTAGE PUMPS

### -sizing chart – PVM SINGLE PHASE PUMPS

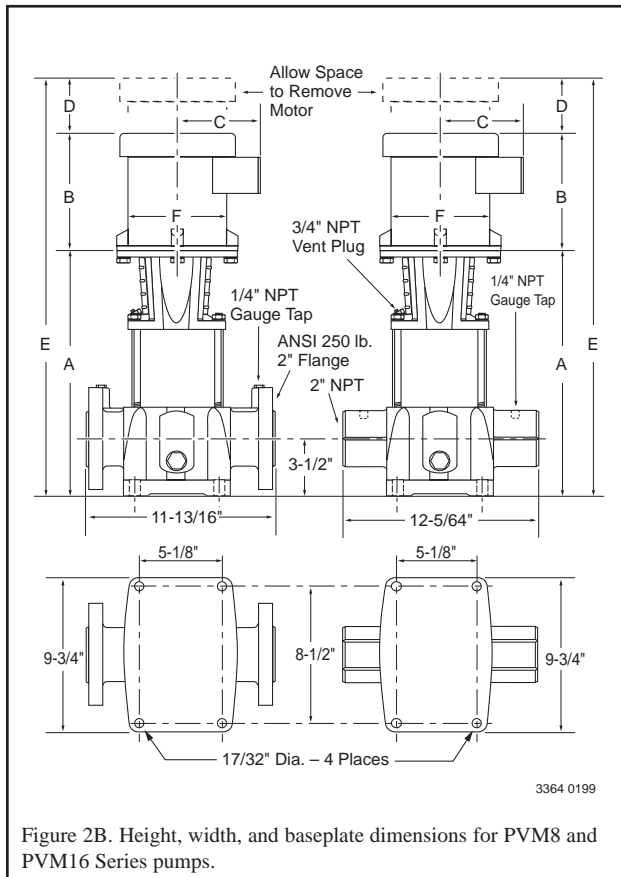
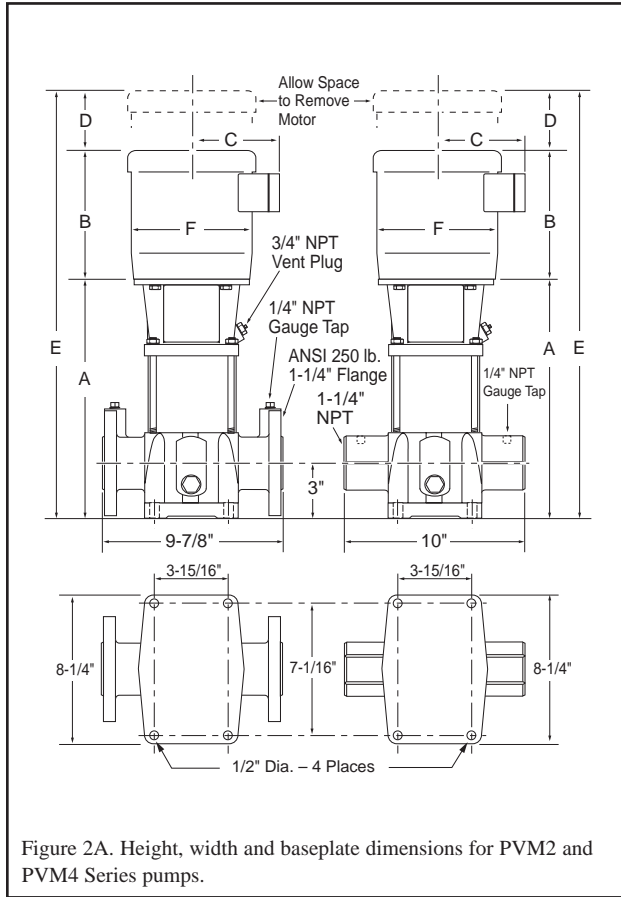

**TABLE I – Maximum Height and Width Dimensions\***

Model Number	Dimension in Inches					
	A	B	C	D	E	F
PVM2-30/2D	11.3	9.3	4.5	2.0	22.6	6.0
PVM2-30D	11.3	9.3	4.5	2.0	22.6	6.0
PVM2-40D	12.1	10.1	5.3	2.0	24.2	7.2
PVM2-50D	12.8	10.1	5.7	2.0	24.9	7.2
PVM2-60D	13.5	10.1	5.7	2.0	25.6	7.2
PVM2-70D	14.2	10.1	5.7	2.0	26.3	7.2
PVM2-80D	14.9	10.1	5.7	2.0	27.0	7.2
PVM2-90D	15.8	12.6	6.8	2.6	31.0	8.9
PVM2-100D	16.5	12.6	6.8	2.6	31.7	8.9
PVM2-110D	17.2	12.6	6.8	2.6	32.4	8.9
PVM2-120D	17.9	12.6	6.8	2.6	33.1	8.9
PVM2-130D	18.6	13.9	7.9	2.6	35.1	10.0
PVM2-140D	19.3	13.9	7.9	2.6	35.8	10.0
PVM2-150D	20.0	13.9	7.9	2.6	36.5	10.0
PVM2-160D	20.8	13.9	7.9	2.6	37.3	10.0
PVM2-170D	21.5	13.9	7.9	2.6	38.0	10.0
PVM2-180D	22.2	13.9	7.9	2.6	38.7	10.0
PVM4-20/1D	11.3	9.3	4.5	2.0	22.6	6.0
PVM4-20D	11.3	9.3	4.5	2.0	22.6	6.0
PVM4-30D	12.4	10.1	5.3	2.0	24.5	7.2
PVM4-40D	13.5	10.1	5.7	2.0	25.6	7.2
PVM4-50D	14.5	10.1	5.7	2.0	26.6	7.2
PVM4-60D	15.8	13.9	7.9	2.6	32.3	10.0
PVM4-80/7D	17.9	13.9	7.9	2.6	34.4	10.0
PVM4-80D	17.9	13.9	7.9	2.6	34.4	10.0
PVM4-90D	19.0	13.9	7.9	2.6	35.5	10.0
PVM4-100D	20.0	13.9	7.9	2.6	36.5	10.0
PVM4-110D	21.1	13.9	7.9	2.6	37.6	10.0
PVM4-120D	22.2	13.9	7.9	2.6	38.7	10.0
PVM4-130D	23.2	13.9	7.9	2.6	39.7	10.0
PVM4-140D	24.3	13.9	7.9	2.6	40.8	10.0
PVM4-150D	25.4	13.9	7.9	2.6	41.9	10.0
PVM4-160D	26.4	13.9	7.9	2.6	42.9	10.0
PVM8-20/1D	14.1	9.3	4.5	2.0	25.4	6.0
PVM8-20D	15.2	10.1	5.7	2.0	27.3	7.2
PVM8-30D	16.4	13.9	7.9	2.6	32.9	10.0
PVM8-40D	17.6	13.9	7.9	2.6	34.1	10.0
PVM8-50D	18.8	13.9	7.9	2.6	35.3	10.0
PVM8-60D	20.0	13.9	7.9	2.6	36.5	10.0
PVM8-70D	21.1	13.9	7.9	2.6	37.6	10.0
PVM8-80D	22.3	13.9	7.9	2.6	38.8	10.0
PVM8-90D	23.5	13.9	7.9	2.6	40.0	10.0
PVM8-100D	24.7	13.9	7.9	2.6	41.2	10.0
PVM8-110D	25.9	13.9	7.9	3.1	42.9	10.0
PVM8-120D	27.0	13.9	7.9	3.1	44.0	10.0
PVM8-130D	28.2	13.9	7.9	3.1	45.2	10.0
PVM8-140D	29.4	13.9	7.9	3.1	46.4	10.0
PVM16-30/2D	15.8	13.9	7.9	2.6	32.3	10.0
PVM16-30D	17.6	13.9	7.9	2.6	34.1	10.0
PVM16-40D	19.4	13.9	7.9	2.6	35.9	10.0
PVM16-50D	21.1	13.9	7.9	3.1	38.1	10.0

\* Measurements represent the largest number possible for each model.

3364 0199

## VERTICAL MULTISTAGE PUMPS

### -sizing chart – PVM THREE PHASE PUMPS

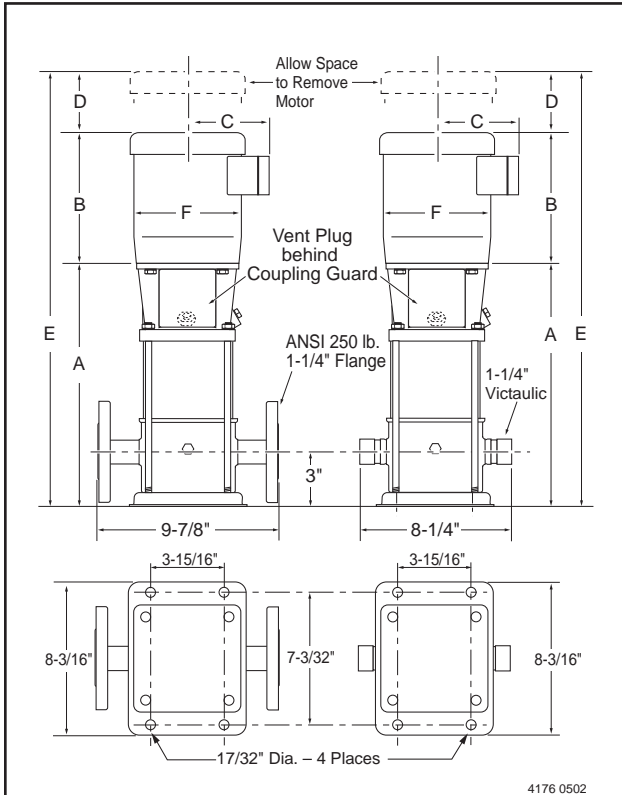

Figure 3A. Height, width and baseplate dimensions for PVMX2 and PVMX4 Series pumps.

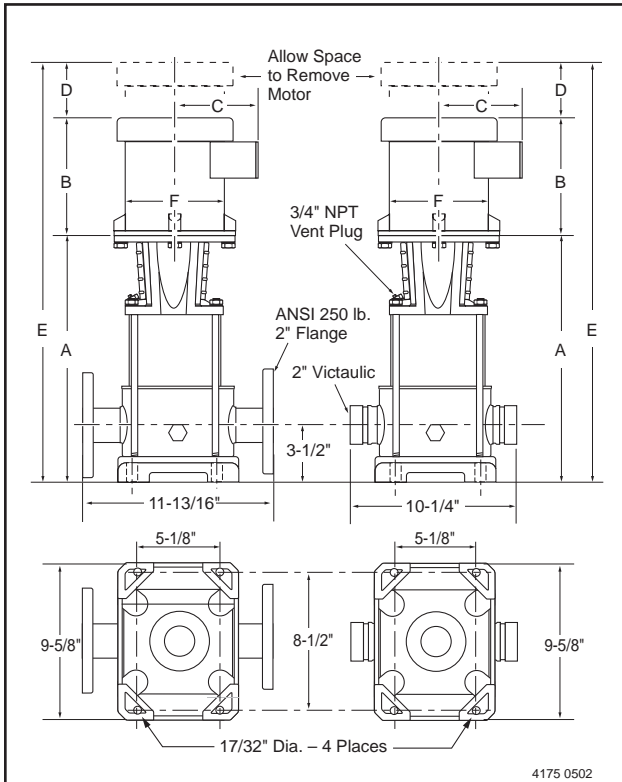

Figure 3B. Height, width, and baseplate dimensions for PVMX8 and PVMX16 Series pumps.

TABLE II – Maximum Height and Width Dimensions\*

Model Number	Dimension in Inches					
	A	B	C	D	E	F
PVM2-30/2D	11.3	9.3	5.2	2.0	22.6	6.2
PVM2-30D	11.3	9.3	5.2	2.0	22.6	6.2
PVM2-40D	12.1	9.3	5.2	2.0	23.4	6.2
PVM2-50D	12.8	10.1	5.7	2.0	24.9	7.2
PVM2-60D	13.5	10.1	5.7	2.0	25.6	7.2
PVM2-70D	14.2	10.1	5.7	2.0	26.3	7.2
PVM2-80D	14.9	10.1	5.7	2.0	27.0	7.2
PVM2-90D	15.8	12.6	6.9	2.6	31.0	8.6
PVM2-100D	16.5	12.6	6.9	2.6	31.7	8.6
PVM2-110D	17.2	12.6	6.9	2.6	32.4	8.6
PVM2-120D	17.9	12.6	6.9	2.6	33.1	8.6
PVM2-130D	18.6	12.6	6.9	2.6	33.8	8.6
PVM2-140D	19.3	12.6	6.9	2.6	34.5	8.6
PVM2-150D	20.0	12.6	6.9	2.6	35.2	8.6
PVM2-160D	20.8	12.6	6.9	2.6	36.0	8.6
PVM2-170D	21.5	12.6	6.9	2.6	36.7	8.6
PVM2-180D	22.2	12.6	6.9	2.6	37.4	8.6
PVM4-20/1D	11.3	9.3	5.2	2.0	22.6	6.2
PVM4-20D	11.3	9.3	5.2	2.0	22.6	6.2
PVM4-30D	12.4	9.3	5.2	2.0	23.7	6.2
PVM4-40D	13.5	10.1	5.7	2.0	25.6	7.2
PVM4-50D	14.5	10.1	5.7	2.0	26.6	7.2
PVM4-60D	15.8	12.6	6.9	2.6	31.0	8.6
PVM4-80/7D	17.9	12.6	6.9	2.6	33.1	8.6
PVM4-80D	17.9	12.6	6.9	2.6	33.1	8.6
PVM4-90D	19.0	12.6	6.9	2.6	34.2	8.6
PVM4-100D	20.0	12.6	6.9	2.6	35.2	8.6
PVM4-110D	21.1	12.6	6.9	2.6	36.3	8.6
PVM4-120D	22.2	12.6	6.9	2.6	37.4	8.6
PVM4-130D	23.2	12.6	6.9	2.6	38.4	8.6
PVM4-140D	24.3	12.6	6.9	2.6	39.5	8.6
PVM4-150D	25.4	13.9	8.1	2.6	41.9	10.3
PVM4-160D	26.4	13.9	8.1	2.6	42.9	10.3
PVM8-20/1D	14.1	9.3	4.5	2.0	25.4	6.0
PVM8-20D	15.2	10.1	5.7	2.0	27.3	7.2
PVM8-30D	16.4	12.6	6.9	2.6	31.6	8.6
PVM8-40D	17.6	12.6	6.9	2.6	32.8	8.6
PVM8-50D	18.8	12.6	6.9	2.6	34.0	8.6
PVM8-60D	20.0	12.6	6.9	2.6	35.2	8.6
PVM8-70D	21.1	13.9	8.1	2.6	37.6	10.3
PVM8-80D	22.3	13.9	8.1	2.6	38.8	10.3
PVM8-90D	23.5	13.9	8.1	2.6	40.0	10.3
PVM8-100D	24.7	13.9	8.1	2.6	41.2	10.3
PVM8-110D	25.9	14.2	8.1	3.1	43.2	10.3
PVM8-120D	27.0	14.2	8.1	3.1	44.3	10.3
PVM8-130D	28.2	14.2	8.1	3.1	45.5	10.3
PVM8-140D	29.4	14.2	8.1	3.1	46.7	10.3
PVM8-160D	32.3	20.0	9.5	4.0	56.3	12.9
PVM8-160D	32.3	20.0	9.5	4.0	56.3	12.9
PVM16-30/2D	15.8	12.6	6.9	2.6	31.0	8.6
PVM16-30D	17.6	13.9	8.1	2.6	34.1	10.3
PVM16-40D	19.4	13.9	8.1	2.6	35.9	10.3
PVM16-50D	21.1	14.2	8.1	3.1	38.4	10.3
PVM16-60D	23.4	20.0	9.5	4.0	47.4	12.9
PVM16-70D	25.2	20.0	9.5	4.0	49.2	12.9
PVM16-80D	27.0	20.0	9.5	4.0	51.0	12.9
PVM16-90D	28.7	16.9	9.2	3.8	49.4	11.5
PVM16-100D	30.5	16.9	9.2	3.8	51.2	11.5
PVM16-110D	31.6	20.0	9.5	3.0	54.6	13.3
PVM16-120D	33.4	20.0	9.5	3.0	56.4	13.3
PVM16-130D	35.2	20.0	9.5	3.0	58.2	13.3

\* Measurements represent the largest number possible for each model.

**NOTICE:** PVMX models are 316 stainless steel.

## VERTICAL MULTISTAGE PUMPS

### -sizing chart – PVMX single phase pumps

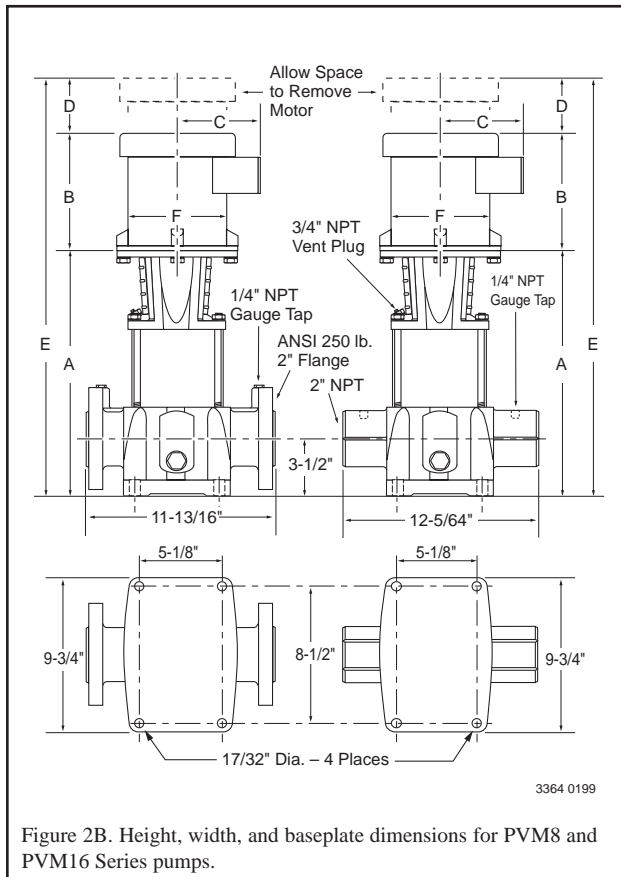
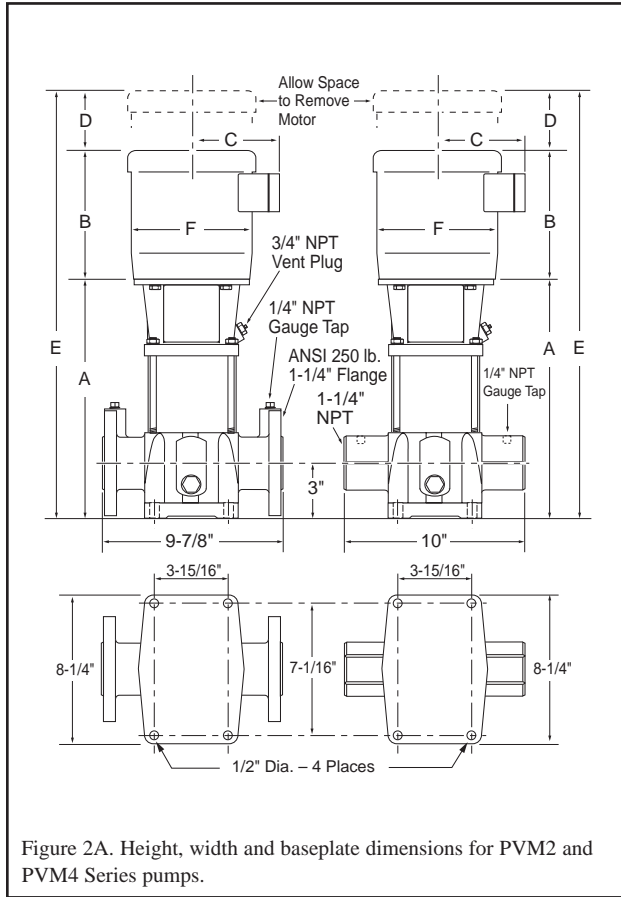

**TABLE I – Maximum Height and Width Dimensions\***

Model Number	Dimension in Inches					
	A	B	C	D	E	F
PVMX2-30/2D	11.9	9.3	4.5	2.0	23.2	6.0
PVMX2-30D	11.9	9.3	4.5	2.0	23.2	6.0
PVMX2-40D	12.6	10.1	5.3	2.0	24.7	7.2
PVMX2-50D	13.3	10.1	5.7	2.0	25.4	7.2
PVMX2-60D	14.1	10.1	5.7	2.0	26.2	7.2
PVMX2-70D	14.8	10.1	5.7	2.0	26.9	7.2
PVMX2-80D	15.5	10.1	5.7	2.0	27.6	7.2
PVMX2-90D	16.2	12.6	6.8	2.6	31.4	8.9
PVMX2-100D	16.9	12.6	6.8	2.6	32.1	8.9
PVMX2-110D	17.6	12.6	6.8	2.6	32.8	8.9
PVMX2-120D	18.3	12.6	6.8	2.6	33.5	8.9
PVMX2-130D	19.0	13.9	7.9	2.6	35.5	10.0
PVMX2-140D	19.7	13.9	7.9	2.6	36.2	10.0
PVMX2-150D	20.4	13.9	7.9	2.6	36.9	10.0
PVMX2-160D	21.1	13.9	7.9	2.6	37.6	10.0
PVMX2-170D	21.8	13.9	7.9	2.6	38.3	10.0
PVMX2-180D	22.6	13.9	7.9	2.6	39.1	10.0
PVMX4-20/1D	11.7	9.3	4.5	2.0	23.0	6.0
PVMX4-20D	11.7	9.3	4.5	2.0	23.0	6.0
PVMX4-30D	12.8	10.1	5.3	2.0	24.9	7.2
PVMX4-40D	13.9	10.1	5.7	2.0	26.0	7.2
PVMX4-50D	14.9	10.1	5.7	2.0	27.0	7.2
PVMX4-60D	16.0	13.9	7.9	2.6	32.5	10.0
PVMX4-80/7D	18.1	13.9	7.9	2.6	34.6	10.0
PVMX4-80D	18.1	13.9	7.9	2.6	34.6	10.0
PVMX4-90D	19.2	13.9	7.9	2.6	35.7	10.0
PVMX4-100D	20.2	13.9	7.9	2.6	36.7	10.0
PVMX4-110D	21.3	13.9	7.9	2.6	37.8	10.0
PVMX4-120D	22.4	13.9	7.9	2.6	38.9	10.0
PVMX4-130D	23.4	13.9	7.9	2.6	39.9	10.0
PVMX4-140D	24.5	13.9	7.9	2.6	41.0	10.0
PVMX4-150D	25.5	13.9	7.9	2.6	42.0	10.0
PVMX4-160D	26.6	13.9	7.9	2.6	43.1	10.0
PVMX8-20/1D	14.1	9.3	4.5	2.0	25.4	6.0
PVMX8-20D	15.2	10.1	5.7	2.0	27.3	7.2
PVMX8-30D	16.4	13.9	7.9	2.6	32.9	10.0
PVMX8-40D	17.6	13.9	7.9	2.6	34.1	10.0
PVMX8-50D	18.8	13.9	7.9	2.6	35.3	10.0
PVMX8-60D	20.0	13.9	7.9	2.6	36.5	10.0
PVMX8-70D	21.1	13.9	7.9	2.6	37.6	10.0
PVMX8-80D	22.3	13.9	7.9	2.6	38.8	10.0
PVMX8-90D	23.5	13.9	7.9	2.6	40.0	10.0
PVMX8-100D	24.7	13.9	7.9	2.6	41.2	10.0
PVMX8-110D	25.9	13.9	7.9	3.1	42.9	10.0
PVMX8-120D	27.0	13.9	7.9	3.1	44.0	10.0
PVMX8-130D	28.2	13.9	7.9	3.1	45.2	10.0
PVMX8-140D	29.4	13.9	7.9	3.1	46.4	10.0
PVMX16-30/2D	15.8	13.9	7.9	2.6	32.3	10.0
PVMX16-30D	17.6	13.9	7.9	2.6	34.1	10.0
PVMX16-40D	19.4	13.9	7.9	2.6	35.9	10.0
PVMX16-50D	21.1	13.9	7.9	3.1	38.1	10.0

\* Measurements represent the largest number possible for each model.

3364 0199

## VERTICAL MULTISTAGE PUMPS

### -sizing chart – PVMX three phase pumps

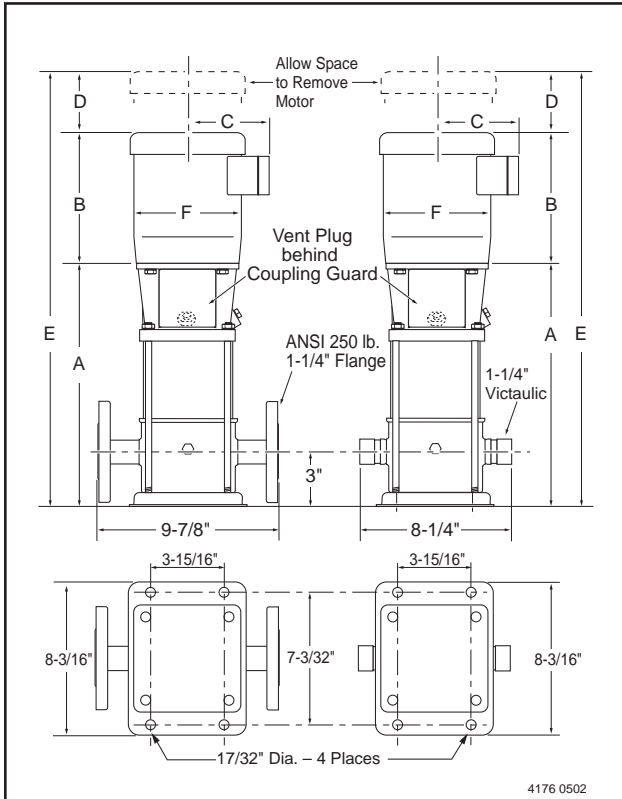

Figure 3A. Height, width and baseplate dimensions for PVMX2 and PVMX4 Series pumps.

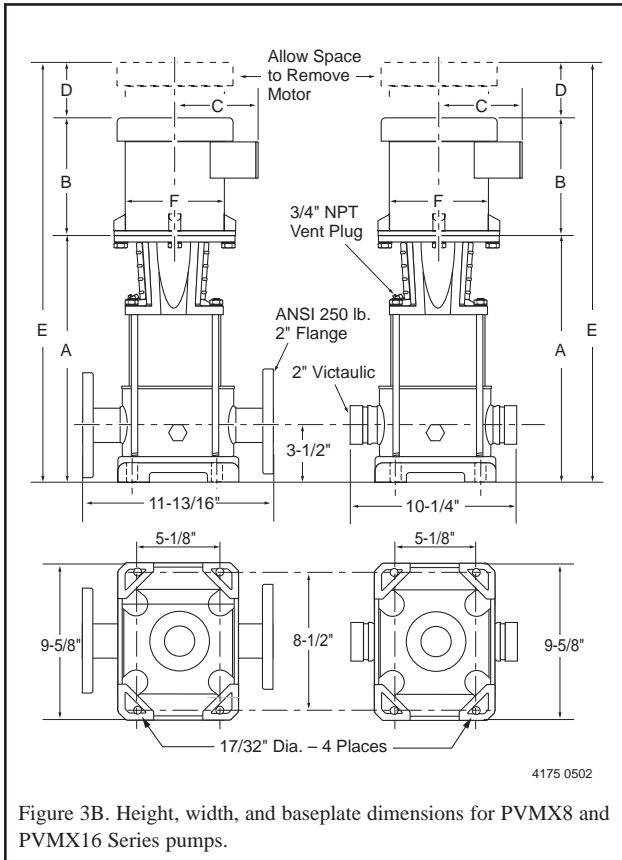

Figure 3B. Height, width, and baseplate dimensions for PVMX8 and PVMX16 Series pumps.

TABLE II – Maximum Height and Width Dimensions\*

Model Number	Dimension in Inches					
	A	B	C	D	E	F
PVMX2-30/2D	11.9	9.3	5.2	2.0	23.2	6.2
PVMX2-30D	11.9	9.3	5.2	2.0	23.2	6.2
PVMX2-40D	12.6	9.3	5.2	2.0	23.9	6.2
PVMX2-50D	13.3	10.1	5.7	2.0	25.4	7.2
PVMX2-60D	14.1	10.1	5.7	2.0	26.2	7.2
PVMX2-70D	14.8	10.1	5.7	2.0	26.9	7.2
PVMX2-80D	15.5	10.1	5.7	2.0	27.6	7.2
PVMX2-90D	16.2	12.6	6.9	2.6	31.4	8.6
PVMX2-100D	16.9	12.6	6.9	2.6	32.1	8.6
PVMX2-110D	17.6	12.6	6.9	2.6	32.8	8.6
PVMX2-120D	18.3	12.6	6.9	2.6	33.5	8.6
PVMX2-130D	19.0	12.6	6.9	2.6	34.2	8.6
PVMX2-140D	19.7	12.6	6.9	2.6	34.9	8.6
PVMX2-150D	20.4	12.6	6.9	2.6	35.6	8.6
PVMX2-160D	21.1	12.6	6.9	2.6	36.3	8.6
PVMX2-170D	21.8	12.6	6.9	2.6	37.0	8.6
PVMX2-180D	22.6	12.6	6.9	2.6	37.8	8.6
PVMX4-20/1D	11.7	9.3	5.2	2.0	23.0	6.2
PVMX4-20D	11.7	9.3	5.2	2.0	23.0	6.2
PVMX4-30D	12.8	9.3	5.2	2.0	24.1	6.2
PVMX4-40D	13.9	10.1	5.7	2.0	26.0	7.2
PVMX4-50D	14.9	10.1	5.7	2.0	27.0	7.2
PVMX4-60D	16.0	12.6	6.9	2.6	31.2	8.6
PVMX4-80/7D	18.1	12.6	6.9	2.6	33.3	8.6
PVMX4-80D	18.1	12.6	6.9	2.6	33.3	8.6
PVMX4-90D	19.2	12.6	6.9	2.6	34.4	8.6
PVMX4-100D	20.2	12.6	6.9	2.6	35.4	8.6
PVMX4-110D	21.3	12.6	6.9	2.6	36.5	8.6
PVMX4-120D	22.4	12.6	6.9	2.6	37.6	8.6
PVMX4-130D	23.4	12.6	6.9	2.6	38.6	8.6
PVMX4-140D	24.5	12.6	6.9	2.6	39.7	8.6
PVMX4-150D	25.5	13.9	8.1	2.6	42.0	10.3
PVMX4-160D	26.6	13.9	8.1	2.6	43.1	10.3
PVMX8-20/1D	14.1	9.3	4.5	2.0	25.4	6.0
PVMX8-20D	15.2	10.1	5.7	2.0	27.3	7.2
PVMX8-30D	16.4	12.6	6.9	2.6	31.6	8.6
PVMX8-40D	17.6	12.6	6.9	2.6	32.8	8.6
PVMX8-50D	18.8	12.6	6.9	2.6	34.0	8.6
PVMX8-60D	20.0	12.6	6.9	2.6	35.2	8.6
PVMX8-70D	21.1	13.9	8.1	2.6	37.6	10.3
PVMX8-80D	22.3	13.9	8.1	2.6	38.8	10.3
PVMX8-90D	23.5	13.9	8.1	2.6	40.0	10.3
PVMX8-100D	24.7	13.9	8.1	2.6	41.2	10.3
PVMX8-110D	25.9	14.2	8.1	3.1	43.2	10.3
PVMX8-120D	27.0	14.2	8.1	3.1	44.3	10.3
PVMX8-130D	28.2	14.2	8.1	3.1	45.5	10.3
PVMX8-140D	29.4	14.2	8.1	3.1	46.7	10.3
PVMX8-150D	31.1	20.0	9.5	4.0	55.1	12.9
PVMX8-160D	32.3	20.0	9.5	4.0	56.3	12.9
PVMX16-30/2D	15.8	12.6	6.9	2.6	31.0	8.6
PVMX16-30D	17.6	13.9	8.1	2.6	34.1	10.3
PVMX16-40D	19.4	13.9	8.1	2.6	35.9	10.3
PVMX16-50D	21.1	14.2	8.1	3.1	38.4	10.3
PVMX16-60D	23.4	20.0	9.5	4.0	47.4	12.9
PVMX16-70D	25.2	20.0	9.5	4.0	49.2	12.9
PVMX16-80D	27.0	20.0	9.5	4.0	51.0	12.9
PVMX16-90D	28.7	16.9	9.2	3.8	49.4	11.5
PVMX16-100D	30.5	16.9	9.2	3.8	51.2	11.5
PVMX16-110D	31.6	20.0	9.5	3.0	54.6	13.3
PVMX16-120D	33.4	20.0	9.5	3.0	56.4	13.3
PVMX16-130D	35.2	20.0	9.5	3.0	58.2	13.3

\* Measurements represent the largest number possible for each model.

NOTICE: PVMX models are 316 stainless steel.

## VERTICAL MULTISTAGE PUMPS

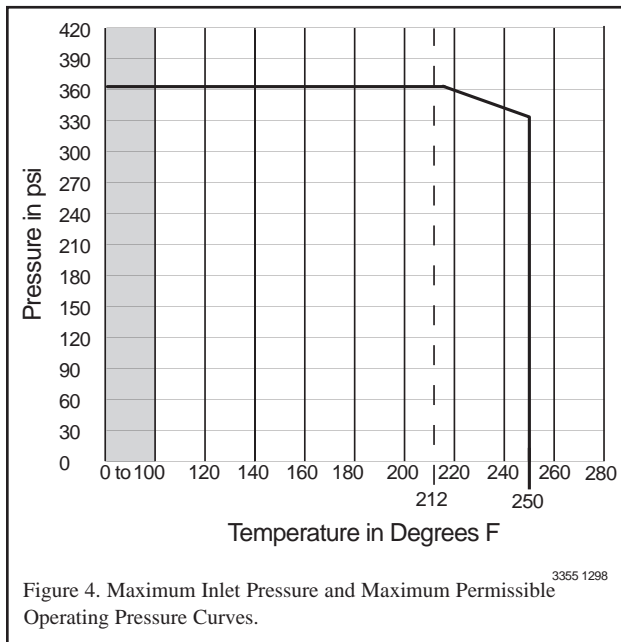

Figure 4. Maximum Inlet Pressure and Maximum Permissible Operating Pressure Curves.

**TABLE III – Permissible Operating Pressure Curves**

Curve 1	Curve 2
PVM2-30/2 to PVM2-120	PVM2-150 to PVM2-180
PVM4-20/1 to PVM4-120	PVM4-140 to PVM4-160
PVM8-20/1 to PVM8-120	PVM8-140 to PVM8-160
PVM16-30/2 to PVM16-80	PVM16-100 to PVM16-120

Model Number		Maximum Inlet Pressure (PSI)
PVM2	30/2 - 60	145
	70 - 180	220
PVM4	20/1 - 20	90
	30 - 80/7 80 - 160	145 220
PVM8	20/1 - 40	90
	50 - 160	145
PVM16	30/2 - 30	90
	40 - 120	145

### INSTALLATION:



#### **Warning: Hazardous Voltage**

Voltage can shock, burn, or cause death. Ground pump motor correctly before connecting to power supply, per article 250-80 of the National Electrical Code (NEC) in the U.S., or the Canadian Electrical Code (CEC), as applicable.

**LOCATION.** Locate pump in a dry, well ventilated area, not subject to freezing or extreme variations in temperature.

Mount pump a minimum of 6" from any obstruction or hot surface. Install the pump with the motor shaft vertical. Make sure that an adequate supply of cool air reaches the motor cooling fan. Maximum ambient air temperature is 104° F (40° C).

For open systems requiring suction lift, locate the pump as close to the water source as possible.

**FOUNDATION.** Foundation should be concrete or a similarly rigid foundation to provide a secure, stable mounting base for the pump.

Secure pump to foundation using all bolt holes. Refer to Figures 2 and 3 for bolt plate dimensions. Be sure that all four pads on the base are properly supported.

Shim pump base to make sure that pump is level.

### PIPING:



#### **Warning: Explosion and Burn Hazard**

Do not run pump with discharge valve closed; the water in the pump may boil, with risk of explosion and steam burns to anyone near.

If there is any danger of the pump running against a closed discharge valve, install a pressure relief or bypass valve in the discharge pipe to allow for minimum liquid flow through the pump. Minimum liquid flow through the pump is needed for cooling and lubrication of the pump (see Table IV). Run the bypass/relief valve and discharge pipe to a floor drain or a tank for collection.

Suction pipe should be adequately sized (see Table V) and run as straight and as short as possible to keep friction losses to a minimum. Pipes, valves, and fittings must have a pressure rating equal to or greater than the maximum system pressure.

**TABLE IV – Minimum Pumping Rates**

Type	Liquid Temperature +5° F to +250° F
PVM2	1 GPM
PVM4	2 GPM
PVM8	4 GPM
PVM16	8 GPM

**TABLE V – Minimum Suction Pipe Sizes**

Type	Pipe Size
PVM2	1-1/4" Nominal Diameter, Schedule 40 Pipe
PVM4	1-1/4" Nominal Diameter, Schedule 40 Pipe
PVM8	2" Nominal Diameter, Schedule 40 Pipe
PVM16	2" Nominal Diameter, Schedule 40 Pipe

Pressure check the discharge piping as required by codes or local regulations.

“Inlet” and “Outlet” are marked on the pump base to show the direction of the liquid flow through the pump.

Install antivibration mountings on either side of the pump if a minimum noise level is desired.

## VERTICAL MULTISTAGE PUMPS

Install isolation valves in both inlet and outlet pipes near the pump (see Figure 5). This allows for removal of pump for service without draining the system and isolation of the pump in case of a flooded suction condition.

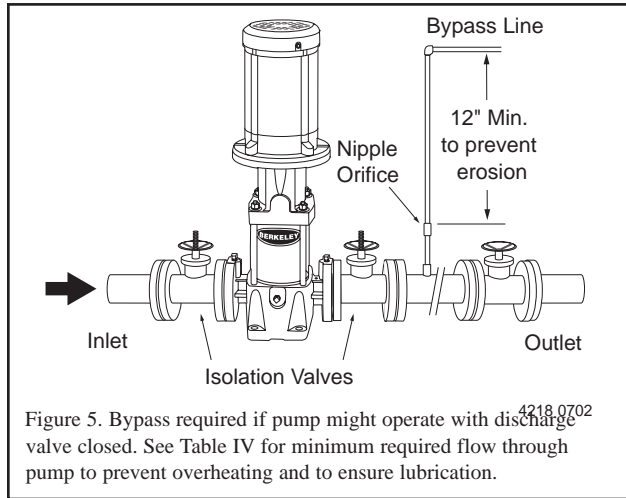

If the system pressure is greater than the pump's maximum inlet pressure, the limits of the pump can be exceeded if the discharge pressure backs up to the inlet side of the pump. Installation of a check valve in the discharge pipe is recommended to prevent this condition.

Make sure, especially on the inlet side of the pump, that there are no airlocks in the system. See Figure 6 for correct pipe work to avoid airlocks. The suction pipe should be level or slightly rising.

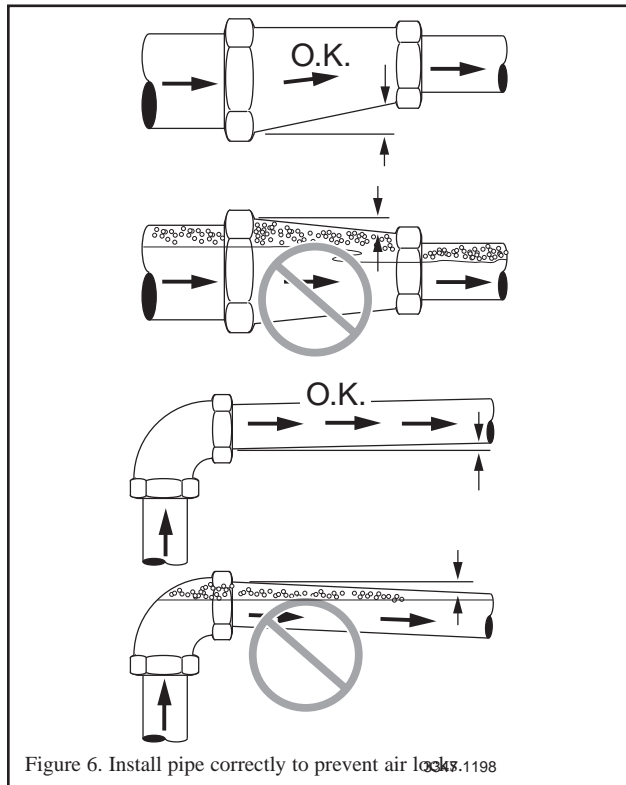

Support all piping independently of the pump so the weight of the piping system does not strain the pump case. Make sure that the expansion and contraction of the piping system from temperature variations cannot put a strain on the pump.

If the system or pump must be drained periodically (especially if the discharge pipe is horizontal or slopes downward away from the pump), install a loop and vacuum valve as shown in Figure 7 to protect the pump against running dry. The highest point of the loop should be at least as high as the lowest point of the motor. This loop/valve combination will allow the pump and the system to be drained independently of one another.

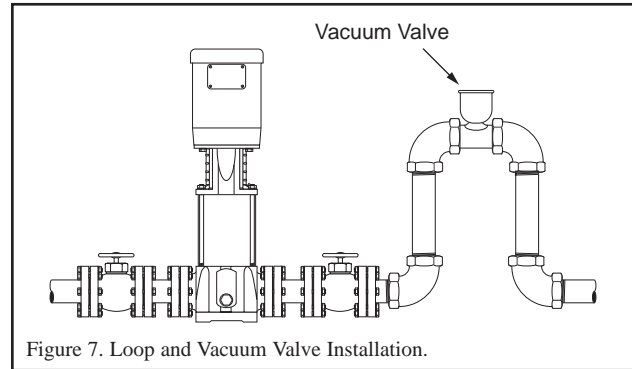

### ELECTRICAL:

**Warning:** Hazardous Voltage

Can shock, burn, or cause death.

All electrical work should be performed by a qualified electrician in accordance with the National Electrical Code and all local codes and regulations. Make sure that the motor voltage, phase, and frequency match the incoming electrical supply. The proper operating voltage and other electrical information can be found on the motor nameplate. These motors are designed to run up to  $\pm 10\%$  of the nameplate-rated voltage. The wiring connection diagram can be found on either a plate attached to the motor or on a diagram inside the terminal box cover.

- If voltage variations are greater than  $\pm 10\%$ , do not operate the pump.
- Incorrect voltage can cause fire or serious damage to the motor and voids warranty.
- Ground the pump motor correctly before connecting it to the power supply.
- Follow the wiring instructions when connecting the motor to the power lines.

**POSITION OF TERMINAL BOX.** To turn the motor so that the terminal box faces the right direction, proceed as follows:

1. Disconnect the power to the pump motor.
2. Remove the coupling guards (use a screwdriver).
3. Remove the couplings.
4. Remove the bolts that fasten the motor to the pump.
5. Turn the motor to the required position (in quarter-turn increments).
6. Follow steps 10–20 under Motor Replacement.



## VERTICAL MULTISTAGE PUMPS

**FIELD WIRING.** All wiring connections and wiring sizes must meet National Electrical Code and local requirements.

**MOTOR PROTECTION.** See the motor nameplate for electrical connection/wiring diagram.

Pentair pumps must be used with the proper size and type of motor starter to ensure protection against damage from low voltage, phase failure, current imbalances, and overloads. The overload should be sized to trip at the full-load current rating of the motor.

### **OPERATION:**

#### **PRIMING.**

#### **Warning: Hazardous Pressure**

Do not run the pump with the discharge valve closed; the water in the pump may boil, causing risk of explosion and steam burns to anyone nearby.

#### **Warning: Hazardous Voltage**

Disconnect all power to the pump before servicing or working on the pump. Make sure that the power is locked out and that the pump cannot be accidentally started.

**NOTICE:** Under no circumstances should the pump be operated without flow through the pump. **Never** operate the pump dry.

#### **Operation of closed systems or open systems with the liquid level above the pump priming plug:**

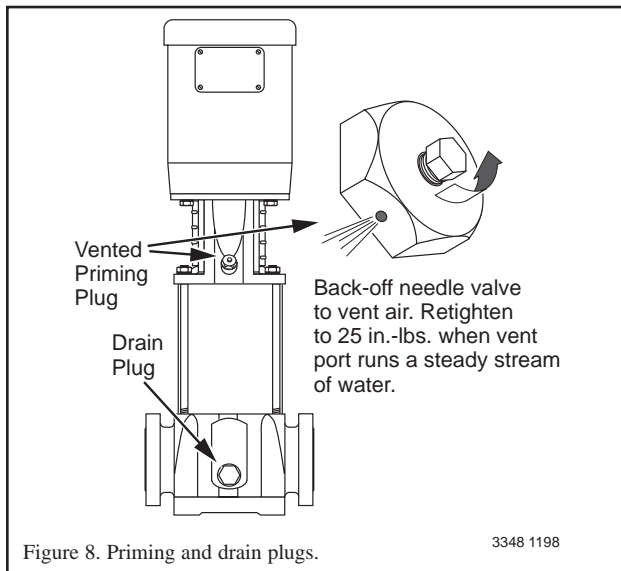

1. Close the discharge isolating valve and loosen the needle valve located in the assembly in the pump head (Figure 8). Do not remove the needle valve.

**NOTICE:** On PVM(X)2/4 models, remove the coupling guard for access to the vent plug.

#### **Warning: Risk of Water Damage and Injury**

Watch the direction of the priming plug and make sure that the liquid escaping from it does not injure persons nearby or damage the motor or other components. In hot water installations, pay particular attention to the risk of injury from scalding hot water.

2. Slowly open the isolation valve in the suction pipe until a steady stream of liquid runs out the vent in the priming port.
3. Tighten needle valve to 25 in.-lbs. Completely open isolation valves.

**NOTICE:** Please turn to *Starting* before proceeding any further.

#### **Operation of open systems with the liquid level below the top of the pump:**

**NOTICE:** The suction pipe requires a check valve or isolation valve.

1. Close the discharge isolation valve.
2. Remove the vented priming plug.
3. Pour liquid through the priming port until the suction pipe and the pump are completely filled with liquid.
4. Replace the vented priming plug and tighten it securely.
5. Repeat steps 1–4 until the pump is primed.

**NOTICE:** Please turn to *Starting* before proceeding any further.

**CHECKING DIRECTION OF ROTATION. NOTICE:** Do not disconnect the motor from the shaft to check the direction of rotation. If you remove the coupling, then you must adjust the shaft position when you reinstall it. This must be done before starting the pump.

Arrows on the pump head show the correct direction of rotation. When seen from the motor fan, the pump should rotate counterclockwise (↺). For pump motors without a fan, remove one of the coupling guards and look at the coupling to determine the direction of rotation. Turn off the pump and replace coupling guard.

**NOTICE:** Do not check the direction of rotation until the pump has been filled with liquid. See *Priming*.

1. Switch power off.
2. Remove the coupling guard and rotate the pump shaft to be certain it can turn freely. Replace the coupling guard.
3. Verify that the electrical connections are in accordance with the wiring diagram on the motor.
4. If the fan is visible, turn on and off to verify rotation.
5. To reverse the direction of rotation, first switch OFF the power supply.
6. On three-phase motors, switch 2 of the 3 power leads on the load side of the starter. On single-phase motors, see the connection diagram on the motor nameplate. Change the wiring as indicated.

## VERTICAL MULTISTAGE PUMPS



### **Warning:** Hazardous Voltage

Voltage can shock, burn, or cause death. Ground pump motor correctly before connecting to power supply, per article 250-80 of the National Electrical Code (NEC) in the U.S., or the Canadian Electrical Code (CEC), as applicable.

- Switch on the power supply and recheck the direction of motor rotation.

#### STARTING.

- If a suction line isolation valve has been installed, check to be sure that it is completely opened.
- For initial starting, the isolation valve in the discharge pipe should be almost closed.
- Start the pump.
- When the piping system has been filled with liquid, slowly open the discharge isolation valve until it is completely open. Opening the valve too fast may result in water hammer in the discharge pipe. If the pump or system starts to rattle, the pump is cavitating; to avoid damage to the pump, reduce the flow through the discharge isolation valve until the rattling stops. If this does not give adequate flow for your installation, call your installer or system designer.
- Record the voltage and amperage of the motor. Adjust the motor overloads if required.
- If pressure gauges have been installed, check and record operating pressures.
- Check all controls for proper operation.

**MOTOR BEARINGS.** For the greasing schedule and greasing procedure of the motor bearings, follow the motor manufacturer's recommendations.

**CALCULATING MINIMUM INLET PRESSURE.** Minimum inlet pressure is required to avoid cavitation in the pump and is calculated as follows:

$$H = P_b - \text{NPSHR} - H_f - H_v - H_s$$

H = Minimum inlet pressure in ft. of head

P<sub>b</sub> = Barometric pressure in ft.

1 Bar = 29.53 inches of mercury (Hg)

1 PSI = 2.31 ft. of head

1 Bar = 33.5 ft. of head

NPSHR = Net positive suction head required. To be read from the NPSHR curve, Figure 9, at the highest flow the pump will be delivering.

H<sub>f</sub> = Friction loss in suction pipe in ft. of head

H<sub>v</sub> = Vapor pressure in ft. of head (see Table VI)

H<sub>s</sub> = A safety margin of 1.64 ft. of head

#### Example for PVM8:

**If:** Flow = 60 GPM

P<sub>b</sub> = 1 Bar = 29.53 inches of mercury\*  
(Convert from Bar to ft. of head)

1 inch of mercury = 1.13 ft. of water

T = 100° F

NPSHR = 10' (see Figure 9)

H<sub>f</sub> = 10' of 2" steel pipe @ 11.9' of loss per 100' of pipe (H<sub>f</sub> = 11.9'/100' = 1.19')

H<sub>v</sub> = 2.195' (from Table VI)

H<sub>s</sub> = 1.64' (safety factor from above)

**Then:** H = 33.5\* - NPSHR\*\* - H<sub>f</sub> - H<sub>v</sub> - H<sub>s</sub>

H = 33.5' - 10' - 1.19' - 2.195' - 1.64 = 18.475'

H = 18.475' = minimum inlet pressure

\* 1 Bar = 14.5 PSI x 2.31 ft. of head = 33.5'

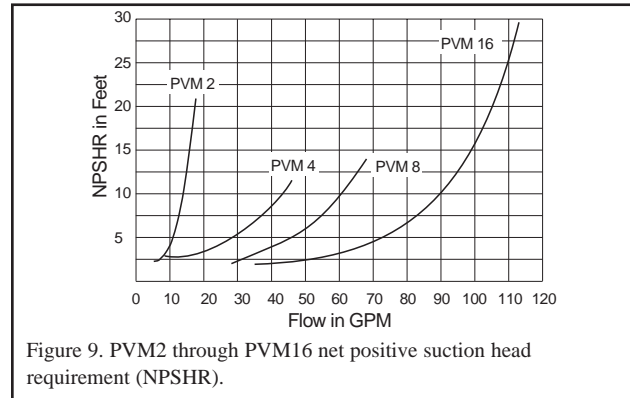

Figure 9. PVM2 through PVM16 net positive suction head requirement (NPSHR).

**TABLE VI – Vapor Pressure of Water**

Temperature in °F (°C)	Vapor Pressure in PSIA (kPa)	Absolute Pressure in Feet (m) of Water
32 (0)	0.089 (.61)	0.205 (.062)
40 (4.4)	0.122 (.84)	0.281 (.086)
60 (15.6)	0.256 (1.77)	0.592 (.180)
80 (26.7)	0.507 (3.65)	1.172 (.358)
100 (37.8)	0.95 (6.55)	2.195 (.669)
120 (48.9)	1.695 (11.69)	3.914 (1.193)
140 (60.0)	2.892 (19.94)	6.681 (2.036)
160 (71.1)	4.745 (32.72)	10.961 (3.341)
180 (82.2)	7.515 (51.84)	17.36 (5.291)
200 (93.3)	11.529 (79.49)	26.632 (8.117)
210 (98.9)	14.125 (97.39)	32.629 (9.945)
<b>212 (100)</b>	<b>14.698 (101.34)</b>	<b>33.952 (10.349)</b>
220 (104.4)	17.188 (118.51)	39.704 (12.102)
230 (110.0)	20.78 (143.28)	48.002 (14.631)
240 (115.6)	24.97 (172.17)	57.681 (17.581)
<b>248 (120.0)</b>	<b>28.79 (188.51)</b>	<b>66.505 (20.271)</b>

## VERTICAL MULTISTAGE PUMPS

### MAINTENANCE:

**MOTOR REPLACEMENT.** For Reference Numbers [shown as (3) or (5)], refer to the Exploded View, Figure 14, for PVM2 and PVM4 series models, Figure 16 for PVMX2 and PVMX4 models, Figure 15 for PVM8 and PVM16 series models, and Figure 17 for PVMX8 and PVMX16 series models.



#### **Warning:** Hazardous Voltage

Disconnect all power to the pump before servicing or working on pump. Make sure that power is locked out and that pump cannot be accidentally started.

1. Disconnect the power to the pump motor.
  2. Close the nearest suction and discharge valves.
  3. Remove the coupling guards (4) by prying them loose with a screwdriver.
  4. Remove the socket head screws (3) and the coupling halves (2) from the shaft (16A). For additional reference, see Figure 12.
- NOTICE:** Socket head screws are metric. See Table VIII for specific metric driver sizes.
5. Remove the shaft pin (5).
  6. Remove the capscrews (12), flatwashers (10), and lockwashers (11) that hold the motor (1) and the motor bracket (7) together.
  7. Pull the old motor up and off the motor bracket. **NOTICE:** Note the location of the conduit box on the motor.
  8. Thoroughly clean the surfaces of the mounting flanges on the new motor and the pump end.
  9. Install the new motor on the pump with the conduit box in the desired position.
  10. Lubricate the capscrews (12) with oil.
  11. Reinstall the lockwashers, flatwashers, and capscrews that hold the motor and the motor bracket together, then tighten evenly and diagonally. See Table VIII for torque specifications.
  12. Reinstall the shaft pin (5) in the shaft.
  13. Reinstall the coupling halves (2) on the pump and motor shaft. Make sure to engage the shaft pin (5).
- NOTICE:** Be sure coupling surfaces are thoroughly clean prior to assembly.
14. Snug up the socket head screws (3) until the coupling begins to bind and then loosen 1/2 turn.
  15. Draw up the capscrews evenly so the gap between the coupling halves is equal on both sides (see Figure 10A).

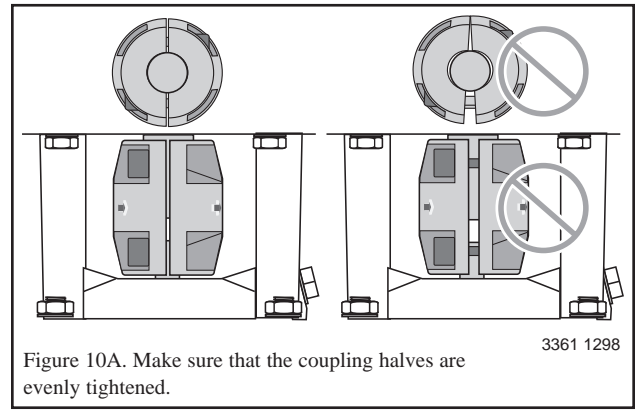

Figure 10A. Make sure that the coupling halves are evenly tightened.

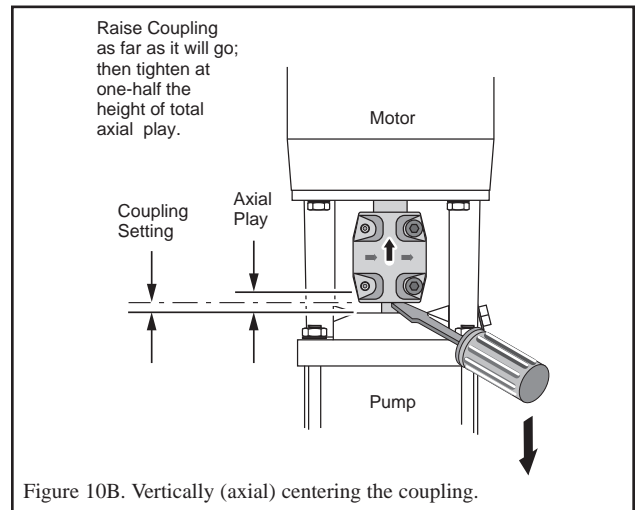

Figure 10B. Vertically (axial) centering the coupling.

16. Insert a screwdriver under the coupling (see Figure 10B).
  17. Raise the pump shaft to its highest point.
  18. Lower the shaft halfway back down the distance you just raised it and retighten the capscrews. See Figure 10.
- NOTICE:** Torque settings are critical to prevent coupling movement. Refer to Table VIII for torque specifications.
19. Rotate the shaft to make sure that there is no interference. If rubbing is noted, repeat steps 16, 17, and 18 above and readjust pump shaft height.
  20. Reinstall the coupling guards by snapping them into place.
- NOTICE:** The guards should be in place before the unit is run.
21. Open the suction and discharge valves. Turn the power back on.

**REPLACING PUMP STACK.** For Reference Numbers [shown as (3) or (5)], refer to the Exploded View, Figure 14 for the PVM2 and PVM4 series models and Figure 15 for PVM8 and PVM16 series models.

## VERTICAL MULTISTAGE PUMPS

**Warning:** Hazardous Pressure

Do not run pump with discharge valve closed; the water in the pump may boil, causing risk of explosion and steam burns to anyone nearby.

1. Follow steps 1–8 under *Motor Replacement*, then proceed with step 2 below.
2. Remove the four staybolt nuts, flatwashers, and lockwashers (8, 9A and 9B) from the staybolts (19).

**NOTICE:** It is not necessary to remove the staybolts when replacing the stack.

3. Lift the motor bracket (7) off the pump body.

**NOTICE:** Note the position of the priming plug. The priming plug must be returned to its original position during reassembly.

4. Remove and discard upper sleeve gasket (17).
5. Clean gasket seat.
6. Remove and replace round spring ring (PVM2 and PVM4) or stack spring (PVM8 and PVM16) (13).
7. Pull the old stack (16A through 16L) out of the stainless steel sleeve (18) by pulling straight up on the pump shaft (16A).
8. Remove the stainless steel sleeve (18).
9. Remove and discard the bottom sleeve gasket (17).

10. Clean the gasket seat.
11. Remove and discard the O-ring (21A) from the suction/discharge (21 - PVM2 and PVM4 only).
12. Cast Iron models only: Clean the O-ring seat and install a new O-ring (21A).
13. Install a new lower sleeve gasket.
14. Install the new stack without the stainless steel sleeve.

**NOTICE:** Be sure to align either the small priming hole or the suction interconnector pin hole (located on the bottom stage of the stack) properly in the base of the Suction/Discharge (21). See Figure 11 (not necessary on PVMX models).

15. Use a rubber mallet to tap the stainless steel sleeve (18) into place.
16. Install a new mechanical shaft seal (14A and 14B or 15A through 15G). Refer to *Mechanical Seal Disassembly* and *Mechanical Seal Reassembly* sections.
17. Install a new upper sleeve gasket (17).
18. Install a new round spring ring or stack spring (13).

19. Reinstall the motor bracket (7) on the pump body. Align the priming plug (6) to its original position.
20. Oil the threads on the staybolts (19).
21. Replace the lockwashers, flatwashers, and staybolt nuts (8, 9A and 9B) and cross-torque the staybolts. See Table VIII for torque specifications.
22. Reinstall the motor (1) on the motor bracket (7) and turn the motor to the desired terminal box position.
23. Follow steps 10–21 under *Motor Replacement*. You have now finished changing out the impeller stack.

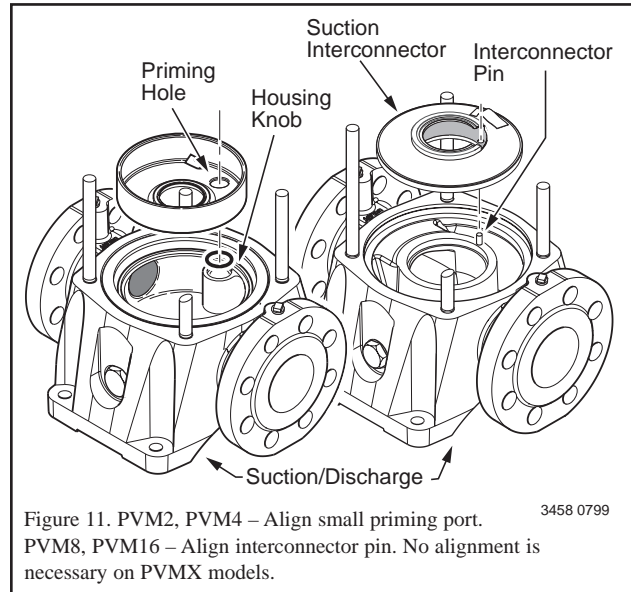

Figure 11. PVM2, PVM4 – Align small priming port. PVM8, PVM16 – Align interconnector pin. No alignment is necessary on PVMX models.

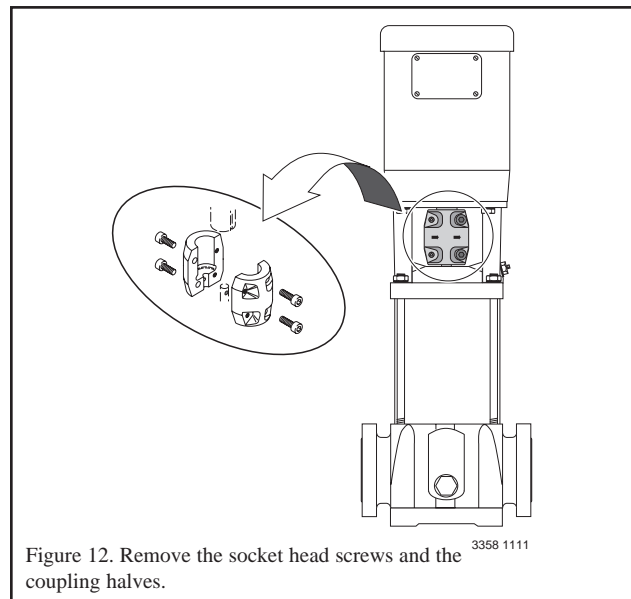

Figure 12. Remove the socket head screws and the coupling halves.

## VERTICAL MULTISTAGE PUMPS

TWO PART MECHANICAL SEAL/DISASSEMBLY. See Table VII to determine which seal your model has.

**TABLE VII – Seal Type Identification**

2 Part Low Pressure Seal	7 Part High Pressure Seal
<b>B78038</b>	<b>B78039</b>
PVM2-30/2 through PVM2-120 PVM4-20/2 through PVM4-120	PVM2-150, PVM2-180 PVM4-140, PVM4-160
<b>B78040</b>	<b>B78041</b>
PVM8-20/1 through PVM8-120 PVM16-30/2 through PVM16-80	PVM8-140, PVM8-160 PVM16-100, PVM16-120

See Figures 14 and 15 for reference numbers.

**NOTICE:** The assembly and disassembly procedure for this seal does not require extraordinary force.



**Warning: Hazardous Voltage**

Can shock, burn, or cause death. Disconnect power to pump before disassembly.

1. Follow steps 1–8 under *Motor Replacement* and proceed with step 2 below.
2. Remove the four nuts, lockwashers, and washers (8, 9A, and 9B) from the staybolts (19).
3. The shaft seal consists of a stationary half (14A) and a rotating half (14B). Turn the motor bracket upside down and remove the stationary part of the seal (14B) from the seal seat in the base of the motor bracket.

**NOTICE:** Use care not to chip or scratch the seal seat during disassembly and assembly.

4. Clean the seal seat with a wet cloth.
5. Remove and discard the rotating parts of the seal by twisting and pulling up on them until they come off the shaft.

TWO PART MECHANICAL SEAL REASSEMBLY.  
**NOTICE:** Before assembly check and clean all sealing and gasket surfaces with a clean wet cloth. Replace all seals, gaskets and O-rings.

1. Turn the motor bracket upside down.
2. Moisten the seal seat (in the motor bracket) and the O-ring (cup seal) portion of the stationary half of the mechanical seal (14A) with a small amount of water.
3. Press the cup-seal onto the stationary half of the shaft seal and then press the shaft seal into the seal seat of the pump head (cup-seal portion first), using finger pressure only.  
**NOTICE:** If a tool is used, protect the seal face from tool with a clean cloth.

**NOTICE:** The cup-seal must be placed evenly on the seal and the seal must be installed evenly in the seal seat to avoid pinching the cup-seal.

4. Moisten the internal parts of the rotating portion of the mechanical seal (14B).
5. Install the rotating half of the seal onto the shaft. Push and twist the seal onto the shaft to the stop ring.

**NOTICE:** Use care when installing the new seal on the shaft. Do not scratch or mar seal on the shaft shoulder.

6. Follow steps 11–23 under *Replacing Pump Stack*.

SEVEN PART MECHANICAL SEAL/DISASSEMBLY. See Figures 14 and 15 for reference numbers.



**Warning: Hazardous Voltage**

Can shock, burn, or cause death. Disconnect power to pump before disassembly.

1. Follow steps 1–8 under *Motor Replacement* and proceed with step 2 below.
2. Remove the four nuts, lockwashers, and washers (8, 9A and 9B) from the staybolts (19).
3. The shaft seal consists of an O-ring (15A), the stationary half of the mechanical seal (15B), the rotating half of the mechanical seal (15C), a second O-ring (15D – inside 15C), a flat washer (15E), a spring (15F), and a mechanical drive ring (15G), in that order; see Figure 13. Turn the pump head upside down and remove the stationary part of the seal (15B) from the seal seat in the base of the motor bracket.

**NOTICE:** Use care not to chip or scratch the seal seat during disassembly and assembly.

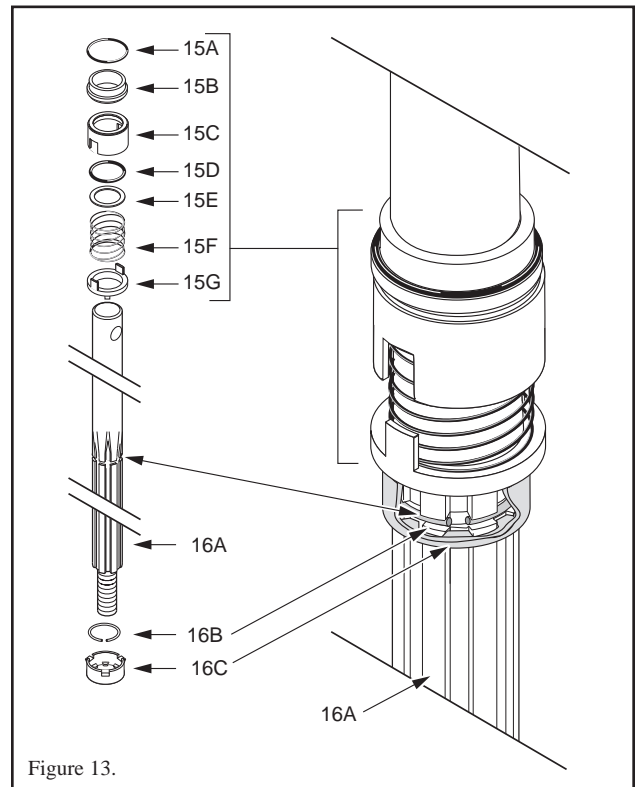

Figure 13.

## VERTICAL MULTISTAGE PUMPS

4. Clean the seal seat with a wet cloth.
5. Remove the rotating parts of the seal by twisting and pulling up on them until they come off the shaft (15C and 15D, 15E, 15F, and 15G). Discard the old seal.

**SEVEN PART MECHANICAL SEAL REASSEMBLY.**  
**NOTICE:** Before assembly check and clean all sealing and gasket surfaces with a clean wet cloth. Replace all seals, gaskets and O-rings.

1. Turn the motor bracket (7) upside down.
  2. Moisten the seal seat (in the motor bracket) with a small amount of water.
  3. Lubricate the larger diameter O-ring (15A) with a small amount of water and install it on the stationary half of mechanical seal (15B).
  4. Press the stationary half of the shaft seal (15B) with O-ring (15A and 15B) into the seal seat of the motor bracket. Use finger pressure only. If a tool is used, protect the seal face from tools with a clean cloth.
- NOTICE:** Be sure the seal is installed evenly to avoid pinching the O-ring.
5. Lubricate smaller diameter O-ring (15D) with water and press it into the rotating half of the mechanical seal (15C).
  6. Install the mechanical drive ring (15G) on the shaft (16A). Be sure the drive ring butts up against the mechanical seal spacer (16C).
  7. Install the spring (15F) up against the drive ring on the shaft.
  8. Install the flatwasher (15E) on the shaft, against the spring.
  9. Install the rotating half of the mechanical seal (15C) on the shaft. Align the grooves on the rotating half of the mechanical seal with the teeth on the mechanical drive ring (15G).
  10. Follow steps 11–23 under *Replacing Pump Stack*.

**FREQUENCY OF STARTS AND STOPS.** Check pump cycling frequency and make sure that the pump is not starting more than:

**TABLE IX – Maximum Number of Cycles**

Cycles	Motor HP Rating
20 times per hour	1/2 – 5 HP motors
15 times per hour	7- 1/2 – 15 HP motors
10 times per hour	20 and 25 HP motors

**FROST PROTECTION.**

1. If you do not use your pump during seasons of frost, drain it and add a glycol based antifreeze (50/50 mixture) to avoid damage.



**Caution:** Risk of Water Damage and Injury

Watch the direction of the priming plug and make sure that liquid escaping from it does not injure persons nearby or damage the motor or other components. In hot water installations, pay particular attention to the risk of injury from scalding hot water.

2. Upon restart dispose of spent antifreeze properly.
3. Do not replace the drain plug or tighten the priming plug until you put the pump back in service again.

**REGULAR MAINTENANCE CHECKS.** The following checks should be made at regular intervals:

1. The pump meets required performance and is operating smoothly and quietly.
2. There are no leaks.
3. The motor is not overheating.
4. Remove and clean all strainers and filters in the system.
5. Verify amp draw – check motor amperage.
6. Pump wear rings and shaft require no regular maintenance.

**TABLE VIII – Torque Specifications (foot-lbs.) For Cast Iron and Stainless Steel Models**

Pump Model Number	Coupling			Motor		Staybolt		Stack Nut	
	Socket Head Screw			Hex Head Capscrew		Hex Nut		Hex Nut	
	M6 x 20	M8 x 25	M10 x 25	3/8 x 1-1/2	1/2 x 1-1/2	1/2 - 13	5/8 - 11	M8	M12
PVM2 Series	15	20	–	30	35	40	–	10	–
PVM4 Series	15	20	–	30	35	40	–	10	–
PVM8 Series	15	20	45	30	35	–	45	–	30
PVM16 Series	–	20	45	–	35	–	45	–	30

**VERTICAL MULTISTAGE PUMPS**  
**TROUBLESHOOTING GUIDE**



**Warning:** Hazardous Voltage and Risk of Sudden Starts

Disconnect all power to the pump before servicing or working on pump. Make sure that power is locked out and that pump cannot be accidentally started.

Fault	Possible Cause
1. Motor does not run when started	<ul style="list-style-type: none"> <li>A. Power failure</li> <li>B. Fuses blown</li> <li>C. Motor starter overload has tripped out</li> <li>D. Main contacts in motor starter are not making contact or the coil is faulty</li> <li>E. Control circuit fuses are defective</li> <li>F. Motor is defective</li> </ul>
2. Motor starter overload trips out immediately when power supply is switched on	<ul style="list-style-type: none"> <li>A. One fuse has blown</li> <li>B. Contacts in motor overload relay are faulty</li> <li>C. Cable connections are loose or faulty</li> <li>D. Motor winding is defective</li> <li>E. Pump mechanically blocked</li> <li>F. Overload setting is too low</li> </ul>
3. Motor starter overload trips out occasionally	<ul style="list-style-type: none"> <li>A. Overload setting is too low</li> <li>B. Low voltage at peak times</li> </ul>
4. Motor starter has not tripped out but the motor does not run	<ul style="list-style-type: none"> <li>A. Check 1A, B, D and E</li> </ul>
5. Pump capacity is not constant	<ul style="list-style-type: none"> <li>A. Pump inlet pressure is too low</li> <li>B. Suction pipe/pump partly blocked</li> <li>C. Pump is sucking air</li> </ul>
6. Pump runs but gives no water	<ul style="list-style-type: none"> <li>A. Suction pipe/pump blocked</li> <li>B. Foot or nonreturn valve is blocked in closed position</li> <li>C. Leakage in suction pipe</li> <li>D. Air in suction pipe or pump</li> <li>E. Motor rotates in the wrong direction</li> </ul>
7. Pump runs backward when switched off	<ul style="list-style-type: none"> <li>A. Leakage in suction pipe</li> <li>B. Foot or nonreturn valve is defective</li> <li>C. Foot valve is blocked in open or partly open position</li> <li>D. Nonreturn valve leaks or is blocked in open or partly open position</li> <li>E. Discharge valve is defective</li> </ul>
8. Leakage from shaft seal	<ul style="list-style-type: none"> <li>A. Pump shaft position is incorrect</li> <li>B. Shaft seal is defective</li> </ul>
9. Noise	<ul style="list-style-type: none"> <li>A. Cavitation is occurring in the pump</li> <li>B. Pump does not rotate freely (there is increased frictional resistance) because of incorrect shaft position</li> </ul>

**VERTICAL MULTISTAGE PUMPS**  
**REPAIR PARTS LIST FOR PVM2 AND PVM4**

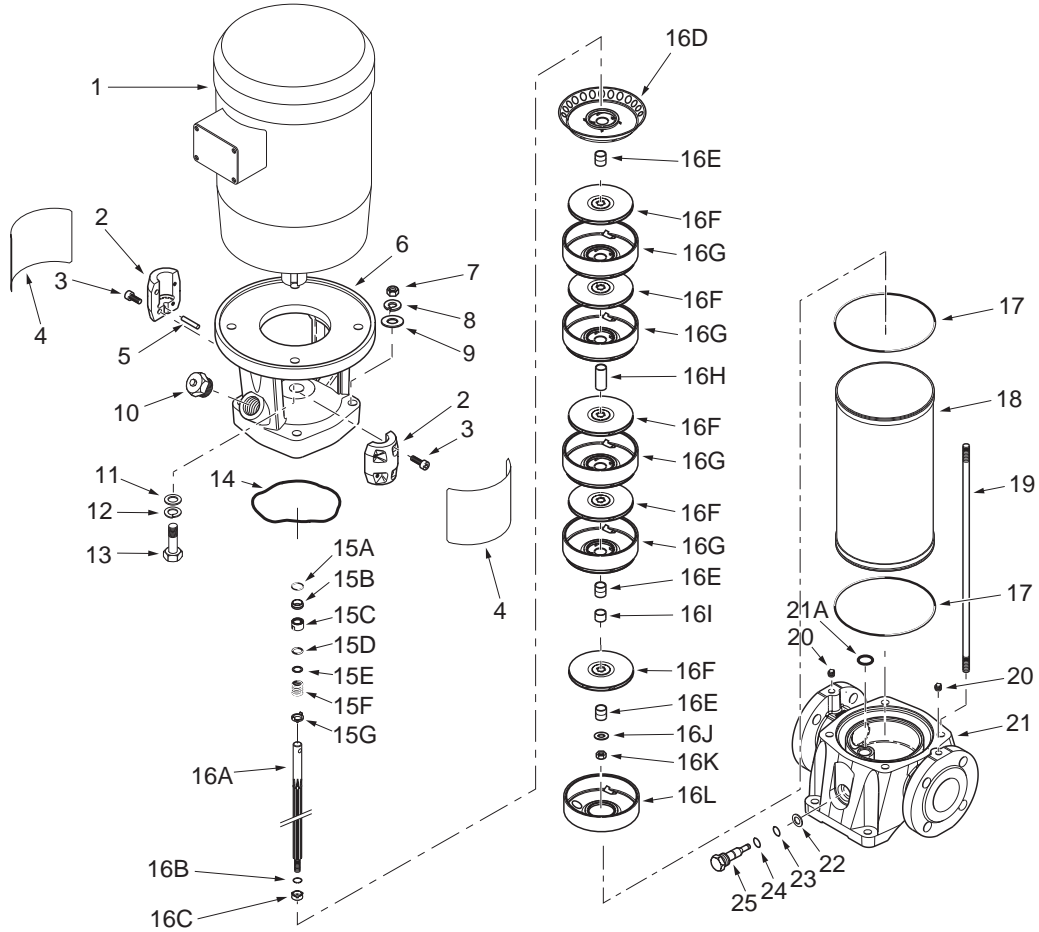

Figure 14. Exploded View of PVM2 and PVM4.

Ref. No.	Description
1	Motor
2	Coupling Half
3	Socket Head Screw
4	Coupling Guard
5	Coupling Pin
6	Vented Priming Plug
7	Motor Bracket
8	Staybolt Nut
9A	Staybolt Lockwasher
9B	Staybolt Flat Washer
10	Flatwasher
11	Lockwasher
12	Capscrew
13	Spring Ring
14	Two part Mechanical Seal (Includes 14A and 14B)
14A	Stationary Half of Mechanical Seal
14B	Rotating Half of Mechanical Seal
15	Seven Part Mechanical Seal (Includes 15A through 15G)
15A	O-Ring, Larger Diameter
15B	Stationary Half of Mechanical Seal
15C	Rotating Half of Mechanical Seal
15D	O-Ring, Smaller Diameter
15E	Flat Washer
15F	Spring

Ref. No.	Description
15G	Mechanical Drive Ring
16	Replacement Stack Kit (Includes Ref. Nos. 16A through 16L)
16A	Shaft
16B	Stop Ring
16C	Mechanical Seal Spacer
16D	Upper Intermediate Chamber
16E	Spacer
16F	Impeller
16G	Diffuser
16H	Spacer
16I	Bearing
16J	Shaft Washer
16K	Nut
16L	Chamber without Diffuser
17	Sleeve Gasket
18	Stainless Steel Sleeve
19	Staybolt
20	Pipe Plug
21	Suction/Discharge
21A	O-Ring (Bottom Chamber)
22	Drain Plug Gasket
23	O-Ring
24	O-Ring
25	Drain Plug



VERTICAL MULTISTAGE PUMPS

**REPAIR PARTS LIST FOR PVM8 AND PVM16**

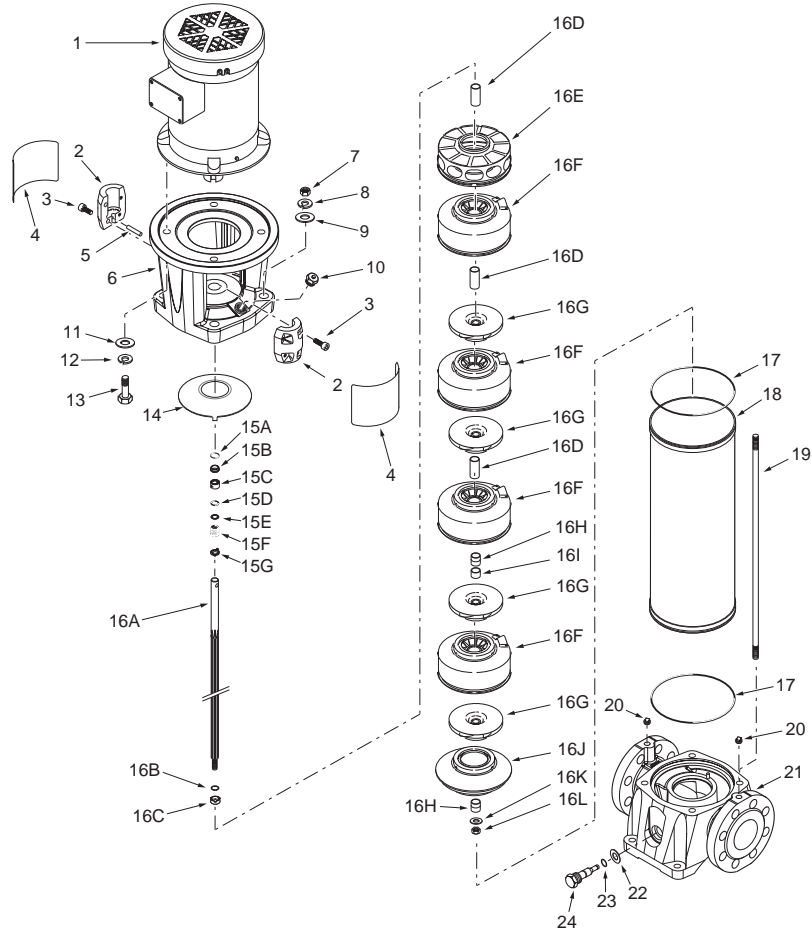

Figure 15. Exploded View of PVM8 and PVM16.

Ref. No.	Description
1	Motor
2	Coupling Half
3	Socket Head Screw
4	Coupling Guard
5	Coupling Pin
6	Vented Priming Plug
7	Motor Bracket
8	Staybolt Nut
9A	Staybolt Lockwasher
9B	Staybolt Flat Washer
10	Flat Washer
11	Lock Washer
12	Capscrew
13	Spring Ring
14	Two Part Mechanical Seal (Includes 14A and 14B)
14A	Stationary Half of Shaft Seal
14B	Rotating Half of Shaft Seal
15	Seven Part Mechanical Seal (Includes 15A through 15G)
15A	O-Ring, Larger Diameter
15B	Stationary Half of Mechanical Seal
15C	Rotating Half of Mechanical Seal
15D	O-Ring, Smaller Diameter
15E	Flat Washer
15F	Spring

Ref. No.	Description
15G	Mechanical Drive Ring
16	Replacement Stack Kit (Includes Ref. Nos. 16A through 16L)
16A	Shaft
16B	Stop Ring
16C	Mechanical Seal Spacer
16D	Upper Intermediate Chamber
16E	Spacer
16F	Impeller
16G	Diffuser
16H	Spacer
16I	Bearing
16J	Shaft Washer
16K	Nut
16L	Chamber without Diffuser
17	Sleeve Gasket
18	Stainless Steel Sleeve
19	Staybolt
20	Pipe Plug
21	Suction/Discharge
21A	O-Ring (Bottom Chamber)
22	Drain Plug Gasket
23	O-Ring
24	O-Ring
25	Drain Plug

**VERTICAL MULTISTAGE PUMPS**  
**REPAIR PARTS LIST FOR PVMX2 AND PVMX4**

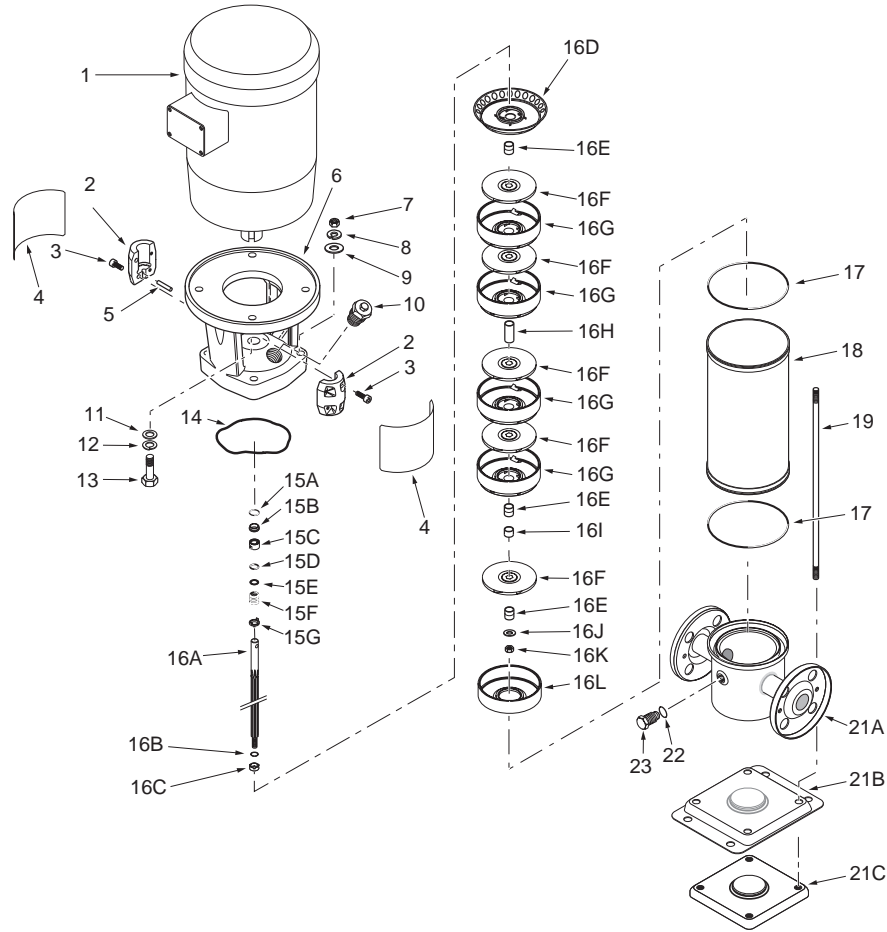

Figure 16. Exploded View of PVMX2 and PVMX4.

Ref. No.	Description
1	Motor
2	Coupling Half
3	Socket Head Screw
4	Coupling Guard
5	Coupling Pin
6	Motor Bracket
7	Staybolt Nut
8A	Staybolt Lockwasher
8B	Staybolt Flat Washer
9	Vented Priming Plug
10	Flatwasher
11	Lockwasher
12	Capscrew
13	Spring Ring
14	Two part Mechanical Seal (Includes 14A and 14B)
14A	Stationary Half of Mechanical Seal
14B	Rotating Half of Mechanical Seal
15	Seven Part Mechanical Seal (Includes 15A through 15G)
15A	O-Ring, Larger Diameter
15B	Stationary Half of Mechanical Seal
15C	Rotating Half of Mechanical Seal
15D	O-Ring, Smaller Diameter
15E	Flat Washer
15F	Spring

Ref. No.	Description
15G	Mechanical Drive Ring
16	Replacement Stack Kit (Includes Ref. Nos. 16A through 16L)
16A	Shaft
16B	Stop Ring
16C	Mechanical Seal Spacer
16D	Upper Intermediate Chamber
16E	Spacer
16F	Impeller
16G	Diffuser
16H	Spacer
16I	Bearing
16J	Shaft Washer
16K	Nut
16L	Chamber without Diffuser
17	Sleeve Gasket
18	Stainless Steel Sleeve
19	Staybolt
21A	Suction/Discharge
21B	Base
21C	Base Reinforcement
22	O-Ring
23	O-Ring
24	Drain Plug (Low Pressure Side)
25	Drain Plug (High Pressure Side)

VERTICAL MULTISTAGE PUMPS

**REPAIR PARTS LIST FOR PVMX8 AND PVMX16**

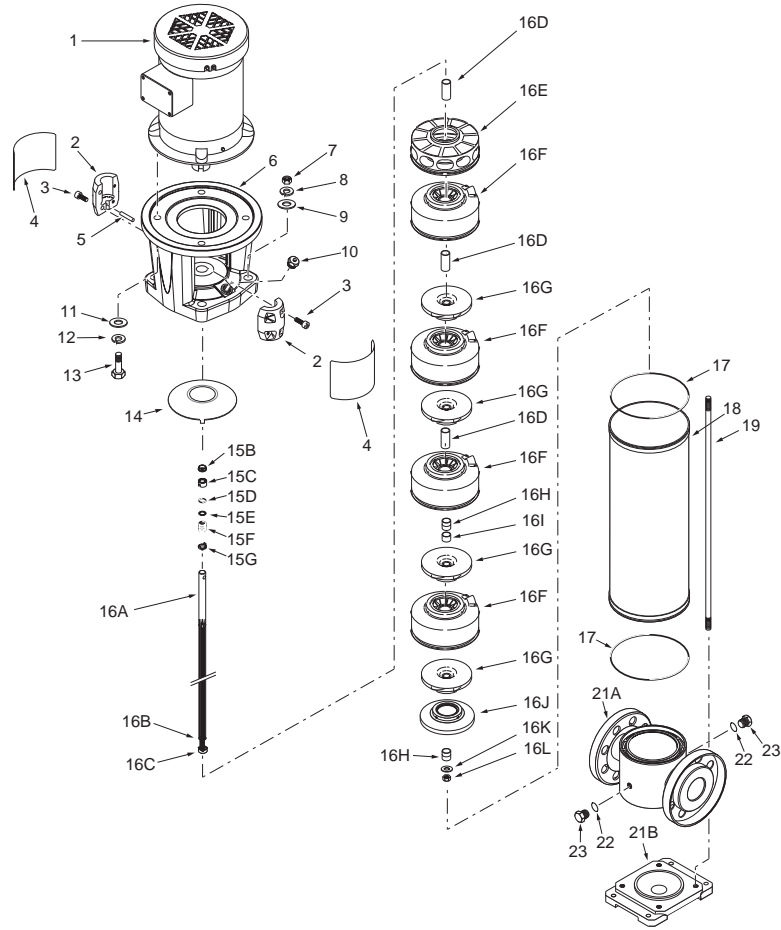

Figure 17. Exploded View of PVMX8 and PVMX16.

Ref. No.	Description
1	Motor
2	Coupling Half
3	Socket Head Screw
4	Coupling Guard
5	Coupling Pin
6	Vented Priming Plug
7	Motor Bracket
8	Staybolt Nut
9A	Staybolt Lockwasher
9B	Staybolt Flat Washer
10	Flat Washer
11	Lock Washer
12	Capscrew
13	Spring Ring
14	Two Part Mechanical Seal (Includes 14A and 14B)
14A	Stationary Half of Shaft Seal
14B	Rotating Half of Shaft Seal
15	Seven Part Mechanical Seal (Includes 15A through 15G)
15A	O-Ring, Larger Diameter
15B	Stationary Half of Mechanical Seal
15C	Rotating Half of Mechanical Seal
15D	O-Ring, Smaller Diameter
15E	Flat Washer
15F	Spring

Ref. No.	Description
15G	Mechanical Drive Ring
16	Replacement Stack Kit (Includes Ref. Nos. 16A through 16L)
16A	Shaft
16B	Stop Ring
16C	Mechanical Seal Spacer
16D	Spacer
16E	Top Diffuser
16F	Diffuser
16G	Impeller
16H	Spacer
16I	Bearing
16J	Suction Interconnector
16K	Washer
16L	Lock Nut
17	Sleeve Gasket
18	Stainless Steel Sleeve
19	Staybolt
21A	Suction/Discharge
21B	Base
22	O-Ring
23	O-Ring
24	Drain Plug (Low Pressure Side)
25	Drain Plug (High Pressure Side)

